













Potable Water Construction Details



	WATER MAIN, PROPOSED
	WATER MAIN, EXISTING
	PLUG
	CAP
	BLOW-OFF ASSEMBLY
	GATE VALVE & BOX
	BUTTERFLY VALVE
	REDUCED PRESSURE ZONE BFP
	DOUBLE CHECK BFP
	AIR RELEASE VALVE
	REDUCER FITTING
	PRESSURE REGULATOR
	POST INDICATOR VALVE

Revision Date:
4/24/06



Gainesville Regional Utilities
Potable Water Construction Details

SYMBOLS

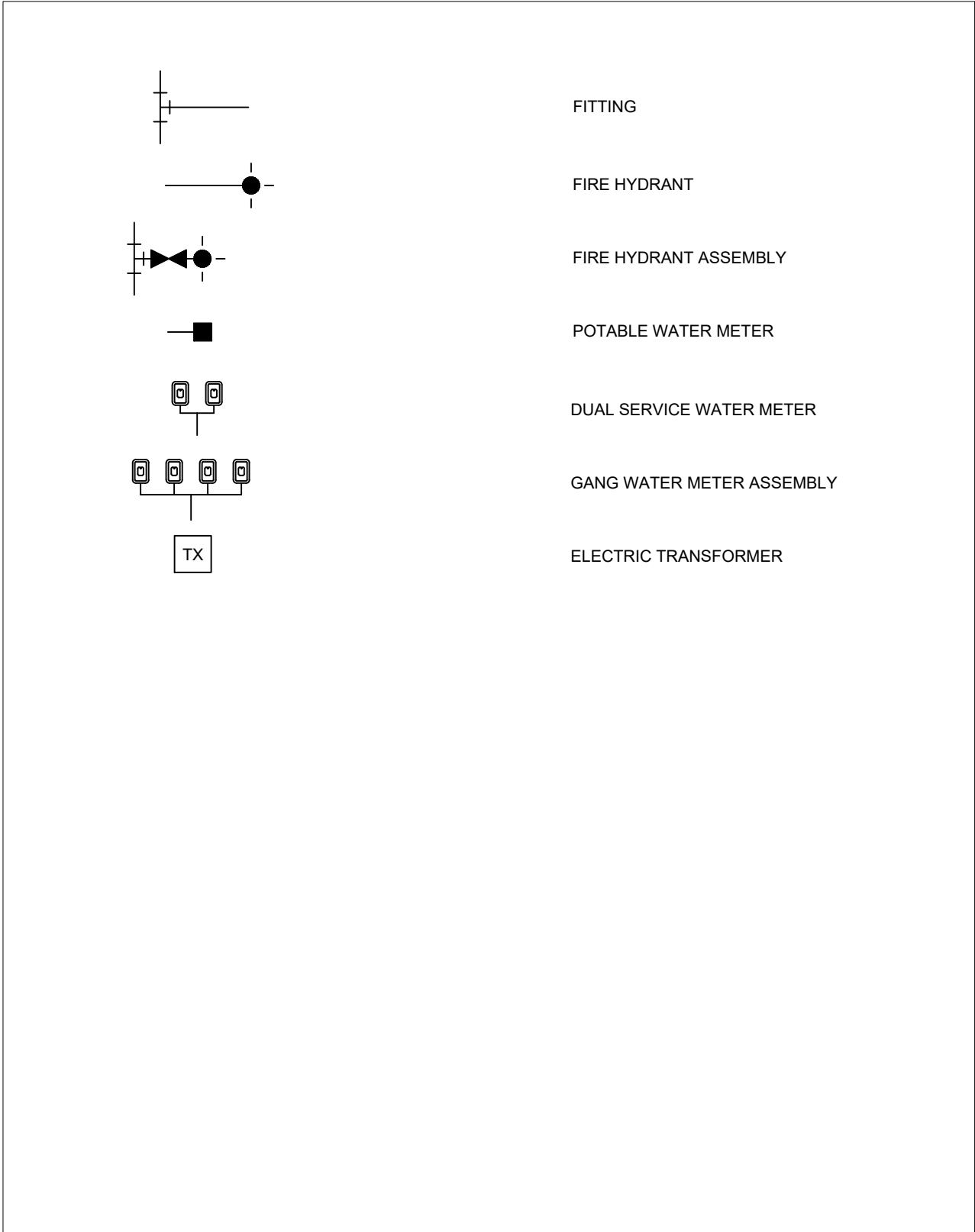

<p>Revision Date: 1/29/2019</p>		<p>Gainesville Regional Utilities Potable Water Construction Details</p> <p>SYMBOLS</p>
-------------------------------------	---	--

PIPE SIZE (IN)	PRESSURE CLASS (PSI)	NOMINAL THICKNESS (IN)
4	350	0.25
6	350	0.25
8	350	0.25
12	350	0.28
16	250	0.30
	300	0.32
	350	0.34
18	250	0.31
	300	0.34
	350	0.36
20	250	0.33
	300	0.36
	350	0.38
24	200	0.33
	250	0.37
	300	0.40
	350	0.43

NOTES:

1. THESE PIPES ARE ADEQUATE FOR THE RATED WORKING PRESSURE PLUS A SURGE ALLOWANCE OF 100 PSI. FIGURE INCLUDES 2.0 SAFETY FACTOR TIMES THE SUM OF WORKING PRESSURE AND 100 PSI SURGE ALLOWANCE OF D.I.P.
2. AN ALLOWANCE FOR SINGLE H-20 TRUCK WITH 1.5 IMPACT FACTOR IS INCLUDED FOR ALL SIZES AND ALL DEPTHS OF COVER.
3. MINIMUM ALLOWABLE DEPTH OF COVER IS 2.5 FEET (*NOTE: MAXIMUM DEPTH OF COVER IS 3 FEET, PER GRU STANDARDS).

<p>Revision Date: 8/22/2016</p>		<p>Gainesville Regional Utilities Potable Water Construction Details GENERAL DATA - DUCTILE IRON PIPE</p>
-------------------------------------	---	--

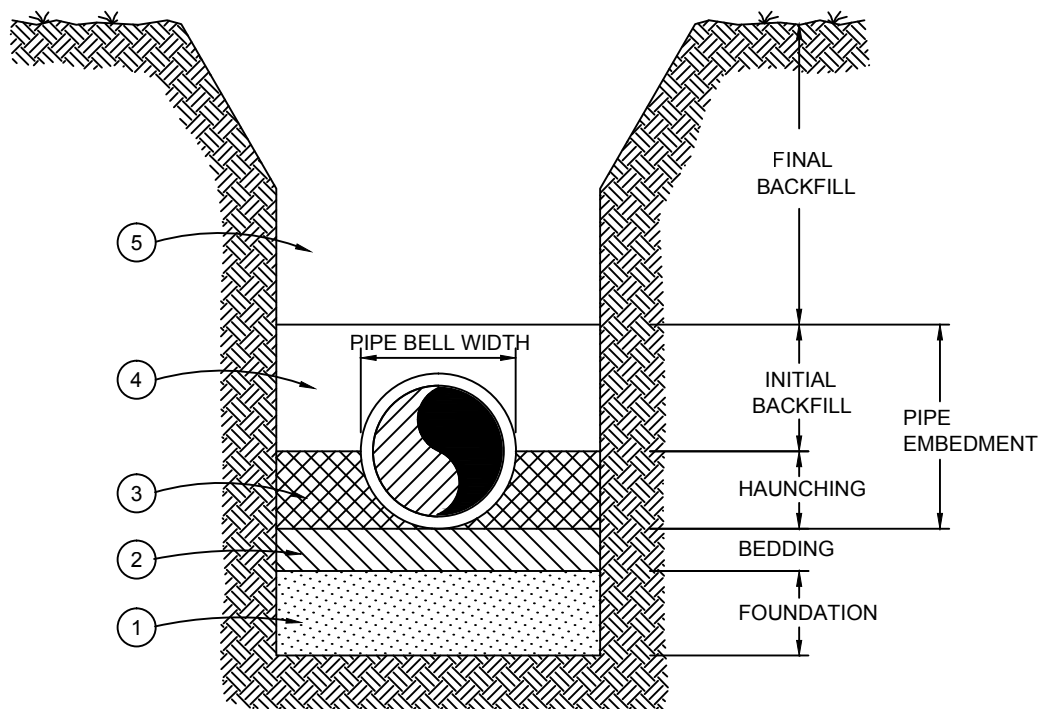

NOTES:

1. A FOUNDATION MAY BE REQUIRED IN VERY POOR SOIL (CLASS IV & V MATERIAL) CONDITIONS. FIELD DETERMINATION WILL BE PROVIDED BY GRU INSPECTOR. TYPICAL FOUNDATION THICKNESS SHALL BE 12", BUT MAY VARY ACCORDING TO NATURAL MATERIAL.
2. BEDDING IS REQUIRED PRIMARILY TO BRING THE TRENCH BOTTOM UP TO GRADE. BEDDING MATERIALS SHALL PROVIDE A UNIFORM AND ADEQUATE LONGITUDINAL SUPPORT UNDER THE PIPE. IN DRY SOIL CONDITIONS CLASS II OR CLASS III MATERIAL SHALL BE HAND PLACED 4" TO 6", LIGHTLY COMPACTED, UNIFORM AND NOT FINER THAN THE FOUNDATION MATERIAL. IN WET SOIL CONDITIONS CLASS I, CLASS II OR CLASS III SHALL BE HAND PLACED, 4" TO 6", UNIFORM AND NOT FINER THAN THE FOUNDATION MATERIAL. WHEN UTILIZING CLASS I MATERIAL, SUFFICIENT AMOUNTS OF CLASS II OR CLASS III MATERIAL SHALL BE ADDED TO FILL ALL VOIDS CREATED BY THE CLASS I MATERIAL.
3. HAUNCHING MATERIAL SHALL BE HAND PLACED TO THE SPRINGLINE OF THE PIPE. CLASS II OR CLASS III MATERIAL SHALL BE CONSOLIDATED UNDER THE PIPE AND HAND TAMPED TO PROVIDE ADEQUATE SIDE SUPPORT.
4. INITIAL BACKFILL MATERIAL SHALL BE CLASS II OR CLASS III. IT SHALL BE HAND PLACED TO 12" ABOVE THE TOP OF THE PIPE. THE SOIL SHALL BE CONSOLIDATED BY HAND TAMPING OR WALKING THE SOIL IN PLACE.
5. FINAL BACKFILL MATERIAL MAY BE MACHINE PLACED. THE MATERIAL SHALL BE CLASS II OR CLASS III MATERIAL. CLASS IV MATERIAL MAY BE INSTALLED OUTSIDE OF THE ROADWAY. FINAL BACKFILL UNDER ROADWAYS MAY REQUIRE SPECIAL COMPACTION AND DENSITY TESTS. REFER TO CITY, COUNTY, OR FDOT STANDARDS, AS APPLICABLE.

<p>Revision Date: 02/20/08</p>		<p>Gainesville Regional Utilities Potable Water Construction Details</p> <p>BACKFILLING REQUIREMENTS</p>
------------------------------------	---	--

PIPE ZONE TERMINOLOGY

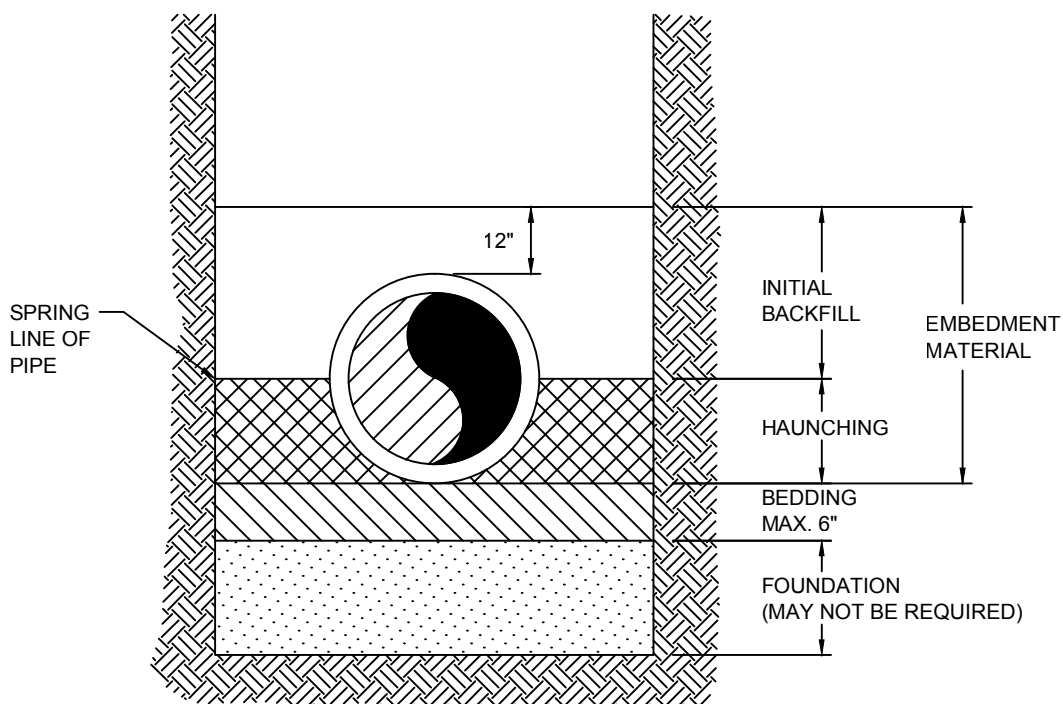

EMBEDMENT MATERIALS

- CLASS I: ANGULAR, 1/4" TO 1-1/2", GRADED STONE, INCLUDING A NUMBER OF FILL MATERIALS THAT HAVE REGIONAL SIGNIFICANCE SUCH AS CORAL, SLAG, CINDERS, CRUSHED STONE AND CRUSHED SHELLS.
- CLASS II: COARSE SANDS AND GRAVELS WITH MAXIMUM PARTICLE SIZE OF 1-1/2", INCLUDING VARIOUS GRADED SANDS AND GRAVELS CONTAINING SMALL PERCENTAGES OF FINES, GENERALLY GRANULAR AND NON-COHESIVE, EITHER WET OR DRY. AASHTO SOIL TYPES A-1 AND A-2 ARE INCLUDED IN THIS CLASS.
- CLASS III: FINE SAND AND CLAYEY GRAVELS, INCLUDING FINE SANDS, SAND-CLAY MIXTURES AND GRAVEL-CLAY MIXTURES. AASHTO SOIL TYPES A-3 AND A-4 ARE INCLUDED IN THIS CLASS.
- CLASS IV: SILT, SILTY CLAYS, AND CLAYS, INCLUDING INORGANIC CLAYS AND SILTS OF MEDIUM TO HIGH PLASTICITY AND LIQUID LIMITS. AASHTO SOIL TYPES A-5, A-6, A-7 AND A-8 ARE INCLUDED IN THIS CLASS. THESE MATERIALS ARE NOT TO BE USED FOR BEDDING, HAUNCHING OR INITIAL BACKFILL.
- CLASS V: THIS CLASS INCLUDES THE ORGANIC SOILS, AS WELL AS SOILS CONTAINING FROZEN EARTH, DEBRIS, ROCKS LARGER THAN 1-1/2" IN DIAMETER AND OTHER FOREIGN MATERIALS. THESE MATERIALS ARE NOT TO BE USED FOR BEDDING, HAUNCHING OR INITIAL BACKFILL.

Revision Date:
02/20/2008



Gainesville Regional Utilities
Potable Water Construction Details
SOIL CLASSIFICATION

NOMINAL PIPE DIAMETER (INCHES)	BEARING AREA REQUIRED (SQ. FT.)				
	DEAD ENDS	11-1/4° BEND	22-1/2° BEND	45° BEND	90° BEND
4	1	1	1	1	2
6	2	1	1	2	3
8	4	1	2	3	5
10	5	1	2	4	7
12	7	2	3	6	10
14	9	2	4	7	13
16	12	3	5	10	17
18	14	3	6	11	20
20	19	4	8	14	26
24	27	6	11	21	37
30	41	8	16	31	57
36	58	12	23	45	82

NOTE: TABLE CALCULATED FOR A SOIL BEARING CAPACITY OF 3000 POUNDS PER SQUARE FOOT AND HYDROSTATIC TEST PRESSURE OF 150 PSI.

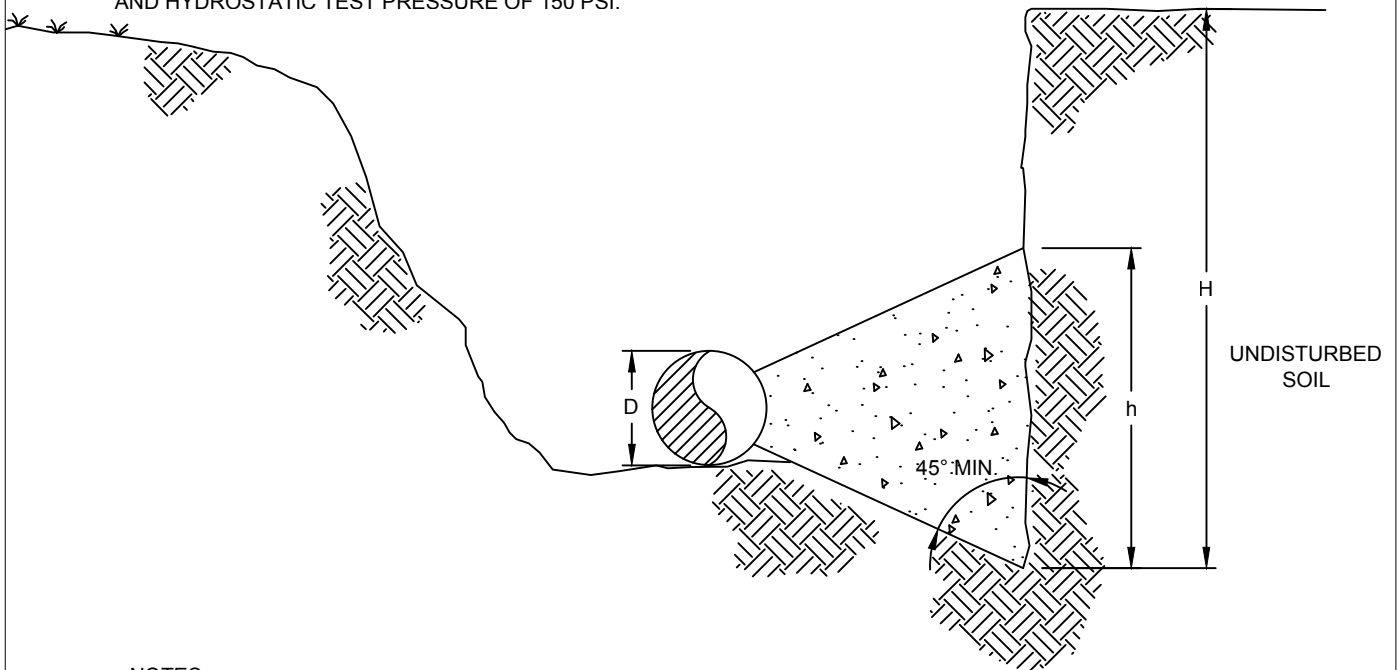

NOTES:

1. THE BLOCK HEIGHT (h) SHOULD BE EQUAL TO OR LESS THAN HALF THE DEPTH OF BURY (H). DO NOT ALLOW (h) TO BE LESS THAN (D) THE DIAMETER OF THE PIPE.
2. BEARING AREA = w x h, WHERE (w) IS THE WIDTH OF THE REACTION BLOCK AGAINST UNDISTURBED SOIL. DETERMINE THE BEARING AREA FROM THE TABLE ABOVE AND DIVIDE BY (h), E.G. FOR A 10" PIPE WITH A 45° BEND, THE REQ'D THRUST BLOCK AREA WOULD BE 4 SQ. FT. (FROM TABLE ABOVE). IF H = 4 FT., THEN h MUST BE BETWEEN 10 IN. (PIPE DIA.) AND 2 FT. (1/2 H). ASSUME h = 2 FT., THEN:
w = BEARING AREA / h = 4 SQ. FT. / 2 FT. = 2 FT.

Revision Date: 02/20/08		Gainesville Regional Utilities Potable Water Construction Details THRUST BLOCK DESIGN - BEARING AREA
----------------------------	---	--

NOMINAL PIPE DIAMETER (IN.)	FORCE = THRUST IN POUNDS AT 150 P.S.I.				
	DEAD ENDS	11-1/4° BEND	22-1/2° BEND	45° BEND	90° BEND
4"	2715	533	1059	2078	3840
6"	5609	1100	2189	4293	7932
8"	9648	1892	3764	7385	13644
10"	14516	2846 *	5663	11110	20528
12"	20528	4025	8009	15711	29030
14"	27428	5376	10700	20993	38789
16"	35669	6992	13914	27300	50442
18"	41798	8782	16305	31992	59111
20"	54965	10775	21441	42071	77732
24"	78419	15372	30591	60021	110900
30"	120638	23648	47061	92336	170691
36"	172814	33875	67414	132266	244394

IN COMPUTING THE THRUST FORCE TO BE RESISTED BY FORCE BLOCKING THE FORMULA $F = 2PA \sin(0/2)$ SHALL BE USED FOR DIFFERENT TYPES OF BENDS AND $F = PA$ FOR DEAD END PIPE.

* EXAMPLE: WITH 10" DIA. D.I.P. (11.1" O.D.) & 11-1/4" BEND.
 $F = 2 \times 150 \text{ P.S.I.} \times (\text{PI} \times (11.1/2) \times \text{SIN}(11.25/2)) = 2846 \text{ LBS.}$

- NOTE: 1. THE SOIL BEARING CAPACITY VALUE MOST COMMONLY USED IN GRU SERVICE AREA 3,000 LB./SQ. FT.
2. THE O.D. OF THE PIPE IS USED IN DETERMINING THE AREA BECAUSE THE PRESSURE IS DISTRIBUTED TO THE GASKET FOR MECHANICAL AND SLIP JOINTS.
3. MULTIPLY TABLE VALUES BY 0.67 TO DETERMINE THE THRUST AT 100 PSI.

Revision Date: 02/20/08		Gainesville Regional Utilities Potable Water Construction Details THRUST BLOCK DESIGN - THRUST FORCE
----------------------------	---	--

BEARING CAPACITIES OF UNDISTURBED SOIL		
SAFE RANGE IN POUNDS PER SQ. FT.	UNDISTURBED SOIL TYPE	
50,000 TO 200,000	LODGE ROCK, GRANITE, TRAP ROCK & SIMILAR	
50,000 TO 60,000	ROCK - EQUAL TO GOOD MASONARY	
30,000 TO 40,000	ROCK - EQUAL TO BEST BRICK	
10,000 TO 20,000	ROCK - EQUAL TO POOR BRICK	
8,000 TO 12,000	CLAY - ALWAYS DRY	
4,000 TO 8,000	CLAY - MODERATELY DRY	
2,000 TO 4,000	CLAY - SOFT	
8,000 TO 10,000	HARDPAN, CEMENTED SAND & GRAVEL	
8,000 TO 12,000	SAND - COMPACTED FIRM	
4,000 TO 8,000	SAND - CLEAN, DRY, MEDIUM, COMPACT	
2,000 TO 4,000	SAND - FINE LOOSE	
1,000 TO 2,000	QUICK SAND, ALLUVIAL SOIL	

NOTES:

1. THE SOIL BEARING CAPACITY VALUE MOST COMMONLY USED IN GRU SERVICE AREA IS 3,000 LB./SQ. FT.

Revision Date: 02/20/08		Gainesville Regional Utilities Potable Water Construction Details <hr/> THRUST BLOCK DESIGN - SOIL BEARING CAPACITY
----------------------------	---	--

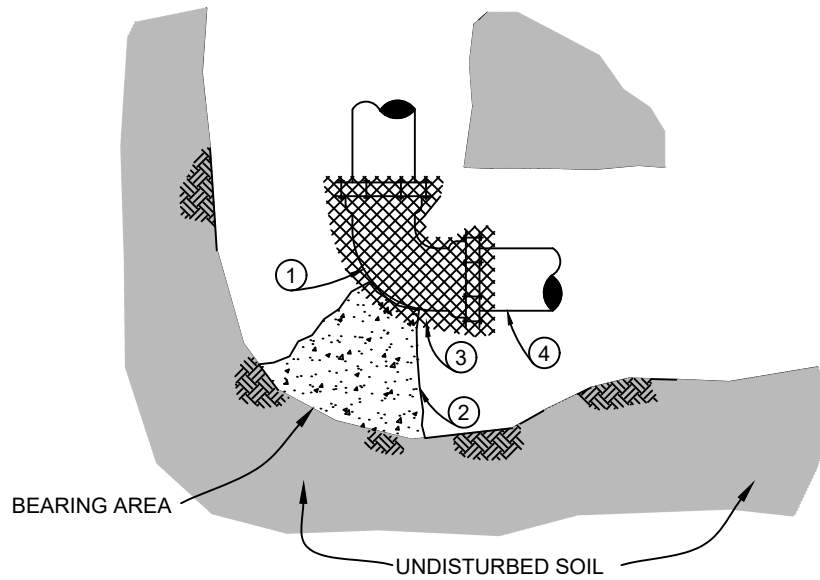

MATERIALS	
ITEM	DESCRIPTION
1	90°, 45°, 22-1/2°, 11-1/4° BEND D.I. MJ
2	CONCRETE 2500 PSI MIN. (FDOT CLASS I)
3	VISQUEEN or FELT 8 MILS THICKNESS (MIN.) or 15 lb (MIN.)
4	PIPE

NOTES:

1. SEE W-2.2 DATA FOR THE BEARING AREA FOR THE CONCRETE REACTION BLOCK.
2. A NON-POROUS MATERIAL SHALL BE PLACED AROUND THE ENTIRE FITTING TO PROTECT THE BOLTS FROM THE CONCRETE.
3. LOCATING WIRE REQUIRED ON ALL PLASTIC WATER MAINS.
4. MECHANICAL RESTRAINT IS REQUIRED IN ALL CASES, UNLESS USE OF A THRUST BLOCK FOR AN EXISTING WATER MAIN IS APPROVED ON A CASE BY CASE BASIS IN WRITING BY GRU WATER & WASTEWATER ENGINEERING.

Revision Date: 01/15/19		Gainesville Regional Utilities Potable Water Construction Details THRUST BLOCK - BEND
----------------------------	---	---

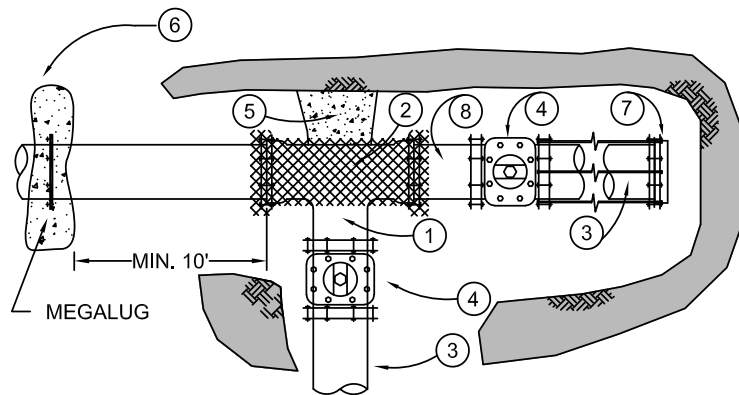

MATERIALS

ITEM	DESCRIPTION	
1	ANCHOR TEE	D.I., M.J.
2	VISQUEEN or FELT	8 MILS THICKNESS (MIN.) or 15 lb (MIN.)
3	PIPE	
4	GATE VALVE	MJ x M.J., MEGALUG (OR APPROVED EQUAL)
5	CONCRETE THRUST BLOCK	2500 PSI MIN. (FDOT CLASS I)
6	CONCRETE WING BLOCK	2500 PSI MIN. (FDOT CLASS I) W/ MEGALUG OR APPROVED EQUAL
7	CAP	D.I., M.J., W/ MEGALUG (EBAA OR APPROVED EQUAL)
8	ANCHOR COUPLING	D.I., M.J., SOLID x SWIVEL

NOTES:

- SEE W-2.2 FOR BEARING AREA REQUIRED.
- A NONPOROUS MATERIAL 8 MILS (MIN.) VISQUEEN OR 15 lb (MIN.) FELT SHOULD BE PLACED BETWEEN THE CONCRETE AND ENTIRE FITTINGS.
- LOCATING WIRE IS REQUIRED ON ALL PLASTIC WATER MAINS.
- MECHANICAL RESTRAINT IS REQUIRED IN ALL CASES, UNLESS USE OF A THRUST BLOCK FOR AN EXISTING WATER MAIN IS APPROVED ON A CASE BY CASE BASIS IN WRITING BY GRU WATER & WASTEWATER ENGINEERING.

Revision Date:
02/06/19



Gainesville Regional Utilities
Potable Water Construction Details

THRUST BLOCK - TEES

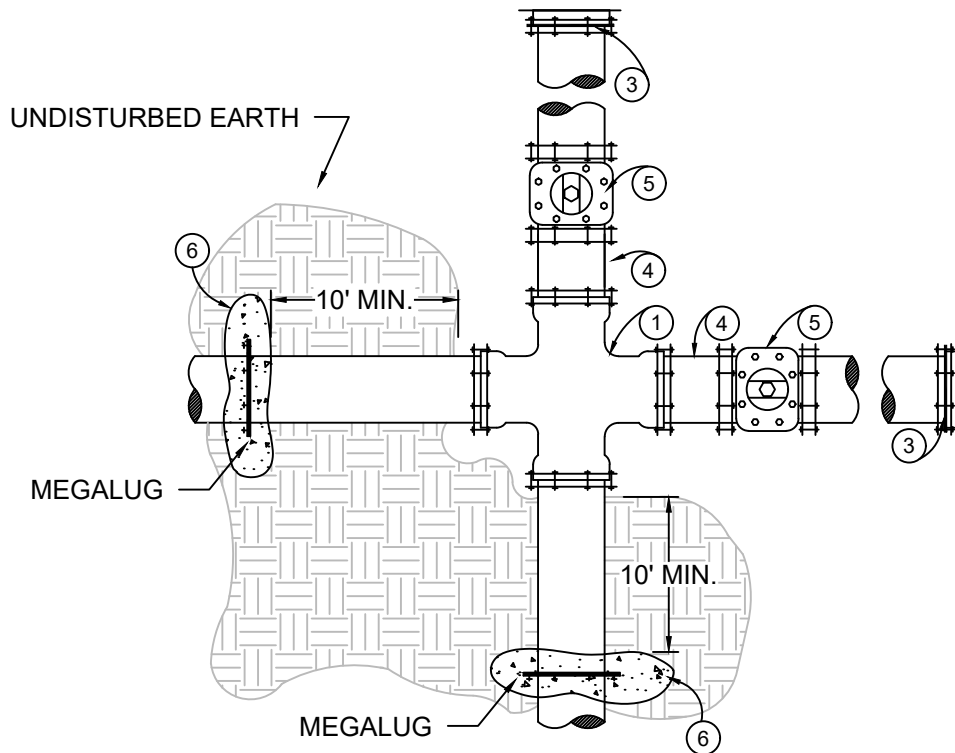

M A T E R I A L S

ITEM	DESCRIPTION
1	CROSS D.I., M.J.
2	CONCRETE 2500 PSI MIN. (FDOT CLASS I)
3	CAP M.J., E.B.A.A. MEGALUG (OR APPROVED EQUAL)
4	ANCHOR COUPLING D.I., M.J., SOLID x SWIVEL
5	GATE VALVE M.J. x M.J., MEGALUG (OR APPROVED EQUAL)
6	CONCRETE WING BLOCK 2500 PSI MIN. (FDOT CLASS I) W/ MEGALUG OR APPROVED EQUAL

NOTES:

1. SEE W-2.2 FOR BEARING AREA REQUIRED.
2. LOCATING WIRE IS REQUIRED ON ALL PLASTIC WATER MAINS
3. MECHANICAL RESTRAINT IS REQUIRED IN ALL CASES, UNLESS USE OF A THRUST BLOCK FOR AN EXISTING WATER MAIN IS APPROVED ON A CASE BY CASE BASIS IN WRITING BY GRU WATER & WASTEWATER ENGINEERING

Revision Date: 02/06/19		Gainesville Regional Utilities Potable Water Construction Details THRUST BLOCK - CROSSES
----------------------------	---	--

NOTE: THIS TABLE IS FOR DIP ONLY; SEE NOTES BELOW FOR PVC

RESTRAIN "A" (LF)									
FITTING	4"	6"	8"	12"	16"	20"	24"	30"	36"
VALVE OR DEAD END	42	58	75	104	131	157	181	213	243
90° BEND	24	33	42	58	72	85	97	112	126
45°/OFFSET	10	14	18	24	30	35	40	47	53
22½° BEND	5	7	9	12	15	17	20	23	26
11¼° BEND	3	4	5	6	8	9	10	12	13

A=MINIMUM FOOTAGE OF PIPE TO BE RESTRAINED.

NOTES:

1. THIS TABLE IS BASED ON THE RESTRAINT CALCULATION SOFTWARE PROVIDED FREE OF CHARGE BY EBAA IRON INC. AT <http://www.ebaa.com/engineering.htm> AND THE FOLLOWING INPUT VARIABLES:
 - A. MAXIMUM TEST PRESSURE OF 150 PSI
 - B. LAYING CONDITION TYPE 3 (SEE DETAILS ON PAGE W-3.0)
 - C. POOR SOIL CONDITIONS (SOIL TYPE ML)
 - D. USING D.I.P.
 - E. 2 FEET OF COVER (NOTE: 2.5 TO 3 FEET OF COVER REQUIRED BY GRU)
 - F. HORIZONTAL BENDS ONLY - ENGINEER TO SUBMIT CALCULATIONS FOR VERTICAL RESTRAINTS
 - G. SAFETY FACTOR = 1.5 TO 1
2. FOR POLYWRAPPED D.I.P., MULTIPLY THE FOOTAGE BY 1.50
3. FOR PVC PIPE DIMENSIONS SEE PAGE W-2.8.1
4. RESTRAINED PIPE SHALL BE MANUFACTURED RESTRAINED PIPE, PUSH-ON RESTRAINTS OR MECHANICAL RESTRAINTS.
5. ANY ADDITIONAL VALVES OR FITTINGS WITHIN THE RESTRAINED SECTION SHALL BE RESTRAINED ACCORDING TO THE LONGER DIMENSION.

Revision Date:
10/19/2018



Gainesville Regional Utilities
Potable Water Construction Details
RESTRAINED JOINT STANDARD
FOR BENDS, VALVES, PLUGS, AND CAPS

NOTE: THESE TABLES ARE FOR PVC PIPE ONLY; SEE W-2.8 OR W-2.9 FOR DIP.

RESTRAIN (LF)									
FITTING SIZE	4"	6"	8"	12"	16"	20"	24"	30"	36"
VALVE OR DEAD END	57	78	101	140	176	211	243	286	326
90° BEND	33	45	57	78	97	114	130	150	169
45°/OFFSET	14	19	24	33	41	47	54	63	71
22½° BEND	7	10	12	16	20	23	27	31	35
11¼° BEND	4	6	7	8	11	12	14	16	18

RESTRAIN (LF)	
FITTING SIZE	REDUCER "B"
6x4	40
8x4	72
8x6	43
12x4	121
12x6	102
12x8	75
16x6	149
16x8	129
16x12	75
20x6	189
20x8	174
20x12	133
20x16	74
24x6	225
24x8	213
24x12	180
24x16	133
24x20	72

RESTRAIN (LF)	
FITTING SIZE	REDUCER "B"
30x6	272
30x8	263
30x12	238
30x16	201
30x20	156
30x24	101
36x6	315
36x8	307
36x12	287
36x16	259
36x20	223
36x24	179
36x30	100

Revision Date:
10/24/18



Gainesville Regional Utilities
Potable Water Construction Details
PVC RESTRAINED JOINT STANDARD
FOR VALVES, BENDS, PLUGS, AND CAPS

NOTE: THESE TABLES ARE FOR DIP ONLY; SEE NOTES W-2.8.1 FOR PVC TABLES

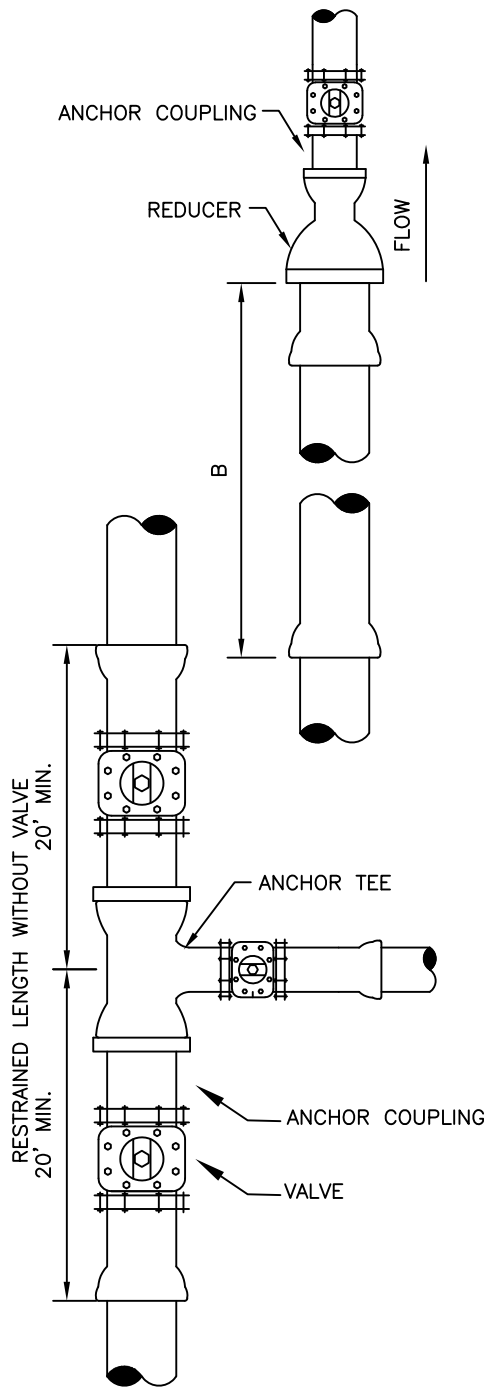

FITTING SIZE	RESTRAIN (LF)	
	REDUCER "B"	
6x4	30	
8x4	54	
8x6	32	
12x4	90	
12x6	76	
12x8	55	
16x6	111	
16x8	96	
16x12	56	
20x6	141	
20x8	130	
20x12	99	
20x16	55	
24x6	168	
24x8	159	
24x12	134	
24x16	99	
24x20	54	

FITTING SIZE	RESTRAIN (LF)	
	REDUCER "B"	
30x6	203	
30x8	196	
30x12	177	
30x16	150	
30x20	116	
30x24	75	
36x6	235	
36x8	229	
36x12	214	
36x16	193	
36x20	166	
36x24	133	
36x30	74	

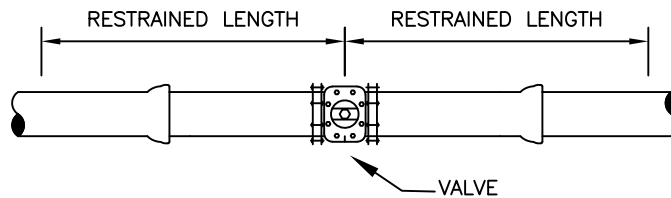

NOTES:

1. THIS TABLE IS BASED ON THE RESTRAINT LENGTH CALCULATOR SOFTWARE PROVIDED FREE OF CHARGE BY EBAA IRON INC. AT <http://www.ebaa.com/engineering.htm> AND THE FOLLOWING INPUT VARIABLES:
 - A. MAXIMUM TEST PRESSURE OF 150 PSI
 - B. LAYING CONDITION TYPE 3 (SEE DETAILS ON PAGE W-3.0)
 - C. POOR SOIL CONDITIONS (SOIL TYPE ML)
 - D. USING D.I.P.
 - E. 2 FEET OF COVER (NOTE: 2.5 TO 3 FEET OF COVER REQUIRED BY GRU)
 - F. HORIZONTAL BENDS ONLY - ENGINEER TO SUBMIT CALCULATIONS FOR VERTICAL RESTRAINTS
 - G. SAFETY FACTOR = 1.5 TO 1
2. FOR POLYWRAPPED D.I.P., MULTIPLY THE FOOTAGE BY 1.50
3. FOR PVC PIPE DIMENSIONS SEE PAGE W-2.8.1
4. RESTRAINED PIPE SHALL BE MANUFACTURED RESTRAINED PIPE, PUSH-ON RESTRAINTS OR MECHANICAL JOINT PIPE RESTRAINED BY EBAA MEGALUG.
5. ANY ADDITIONAL VALVES OR FITTINGS WITHIN THE RESTRAINED SECTION SHALL BE RESTRAINED ACCORDING TO THE LONGER DIMENSION.

Revision Date: 12/11/18		Gainesville Regional Utilities Potable Water Construction Details DIP RESTRAINED JOINT STANDARD FOR TEES AND REDUCERS
----------------------------	--	---

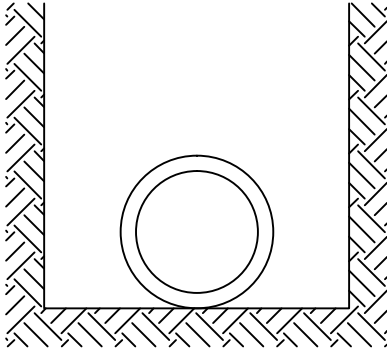

TYPE 1*
FLAT-BOTTOM TRENCH. ** LOOSE
BACKFILL.

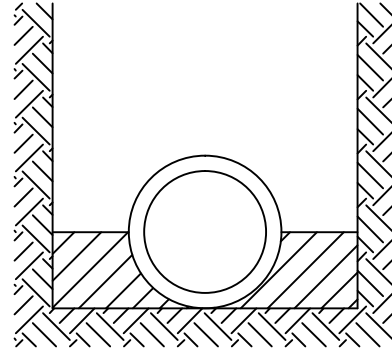

TYPE 2
FLAT-BOTTOM TRENCH. ** BACKFILL
LIGHTLY CONSOLIDATED TO
CENTERLINE OF PIPE.

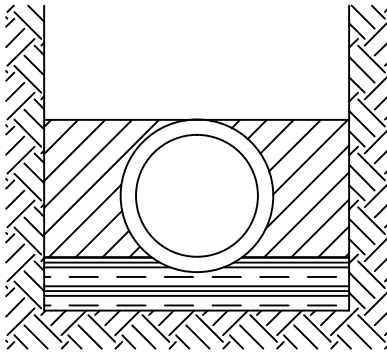

TYPE 3
PIPE BEDDED IN 4-INCH MINIMUM
LOOSE SOIL. *** BACKFILL LIGHTLY
CONSOLIDATED TO TOP OF PIPE.

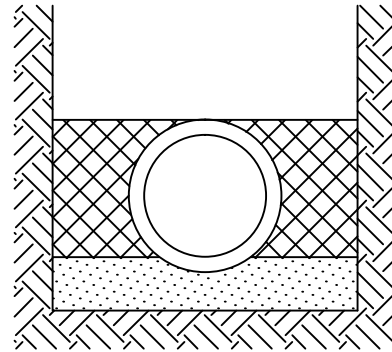

TYPE 4
PIPE BEDDED IN SAND, GRAVEL, OR
CRUSHED STONE TO DEPTH OF 1/8
PIPE DIAMETER, 4-INCH MINIMUM.
BACKFILL COMPACTED TO TOP OF
PIPE (APPROXIMATELY 80% STANDARD
PROCTOR, AASHTO T-99).

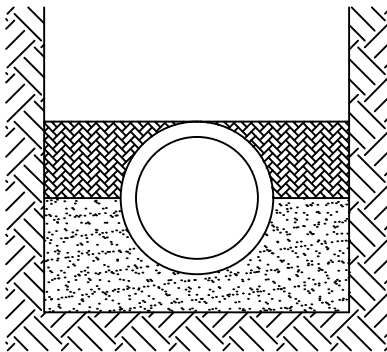

TYPE 5
PIPE BEDDED TO ITS CENTERLINE IN
COMPACTED GRANULAR MATERIAL, 4-INCH
MINIMUM UNDER PIPE. COMPACTED GRANULAR
OR SELECT MATERIAL *** TO TOP OF PIPE
(APPROXIMATELY 90% STANDARD PROCTOR,
AASHTO T-99).

NOTES

CONSIDERATION OF THE PIPE-ZONE EMBEDMENT CONDITIONS INCLUDED IN THIS FIGURE MAY BE INFLUENCED BY FACTORS OTHER THAN PIPE STRENGTH. FOR ADDITIONAL INFORMATION ON PIPE BEDDING AND BACKFILL, SEE ANSI/AWWA C600.

*FOR NOMINAL PIPE SIZES 14-INCH AND LARGER,
**FLAT BOTTOM IS DEFINED AS UNDISTURBED EARTH
CONSIDERATION SHOULD BE GIVEN TO THE USE OF
LAYING CONDITIONS OTHER THAN TYPE 1.

***"LOOSE SOIL" OR "SELECT MATERIAL" IS DEFINED AS "NATIVE SOIL EXCAVATED FROM THE TRENCH, FREE OF ROCKS, FOREIGN MATERIAL, AND FROZEN EARTH".

Revision Date:
02/20/08



Gainesville Regional Utilities
Potable Water Construction Details

PIPE LAYING CONDITIONS

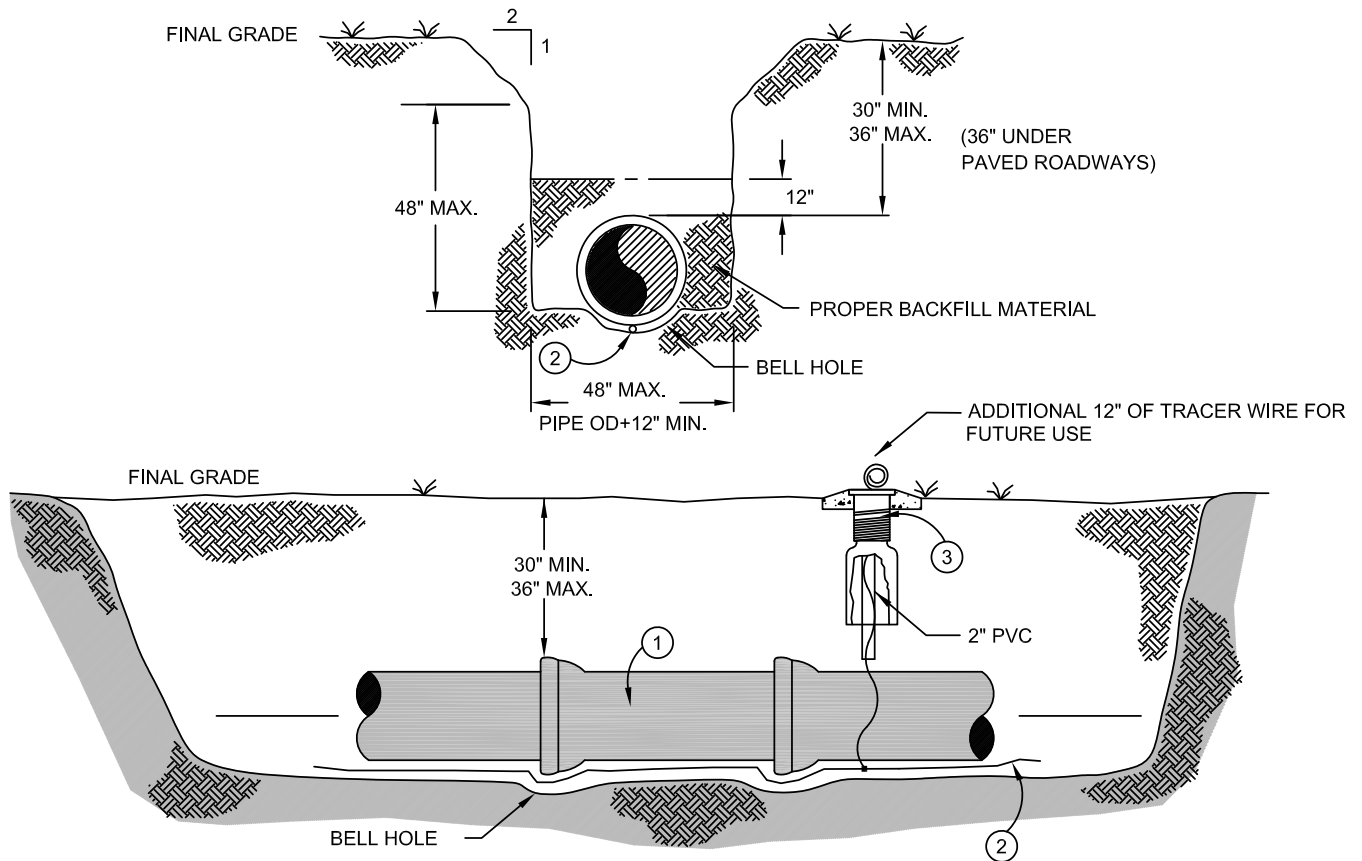

MATERIALS	
ITEM	DESCRIPTION
1	WATER MAIN PIPE
2	TRACER WIRE, BLUE, #10 AWG
3	VALVE BOX

- NOTES:
1. PLASTIC PIPE SHALL REQUIRE AN INSULATED COPPER WIRE TAPED EVERY 10 FEET ON THE BOTTOM OF THE PIPE AND WRAPPED AROUND EACH FIRE HYDRANT AT FINAL GRADE. THE WIRE SHALL BE CONTINUOUS AND ALL SPLICES REQUIRE TRACER-LOCK PART #TL-LUG-SS CONNECTORS. TRACER WIRE SHALL CONTINUE ACROSS DIP SECTIONS OF PIPE, SUCH AS AT ROAD CROSSINGS.
 2. DEPTH OF PIPE MAY BE FIELD ADJUSTED TO MEET SPECIAL CONDITIONS AS DETERMINED BY GRU ENGINEER OR INSPECTOR. PIPE INSTALLED WITH LESS THAN 30" OR GREATER THAN 36" OF COVER SHALL BE DIP.
 3. VALVE BOX SHALL BE INSTALLED AT MAXIMUM 500 Ft. INTERVALS FOR ACCESS FOR CONNECTION AND TESTING OF TRACER WIRE. COIL 12" OF TRACER WIRE INSIDE TOP OF VALVE BOX.

Revision Date: 12/07/18		Gainesville Regional Utilities Potable Water Construction Details WATER MAIN CONSTRUCTION
----------------------------	---	---

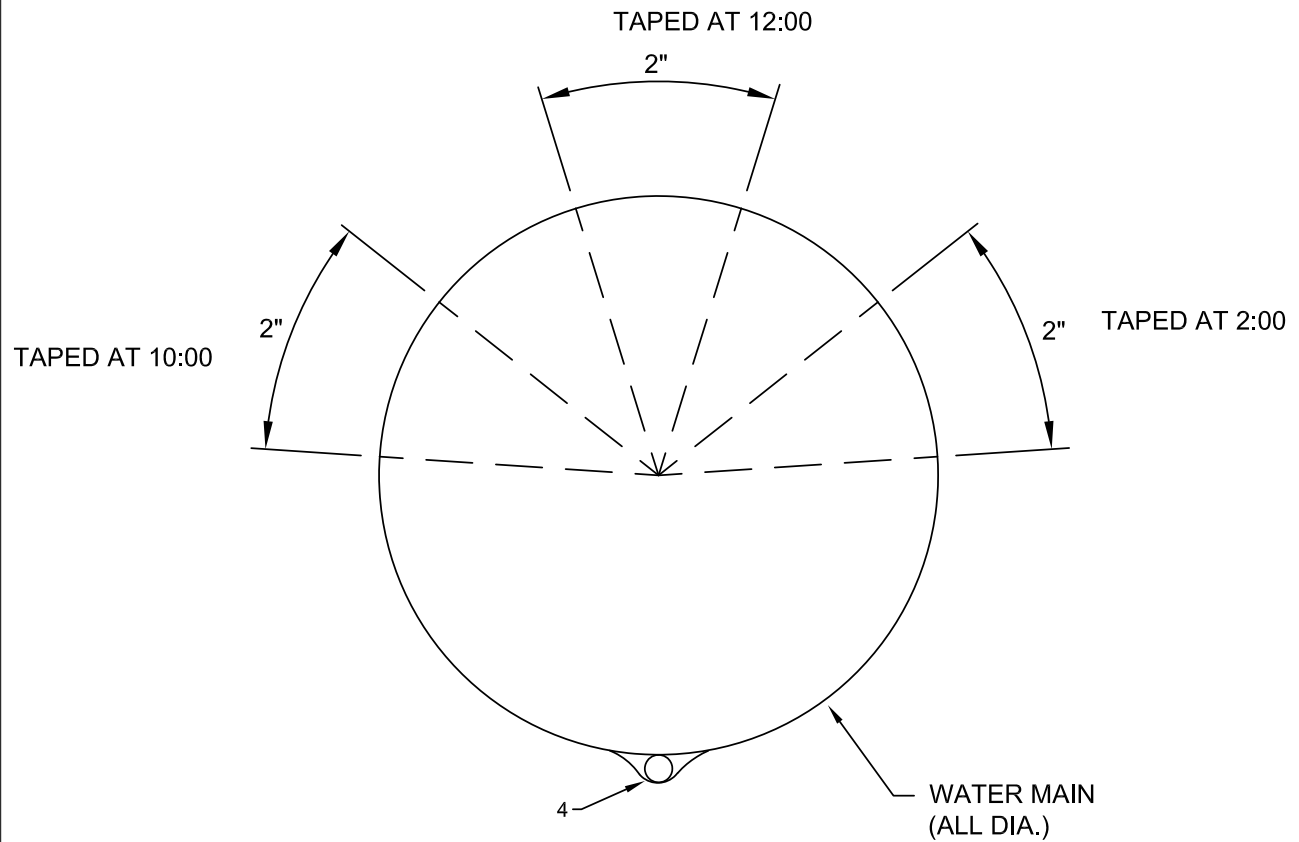

NOTES:

1. PVC PIPE SHALL BE BLUE AND LABELED "POTABLE WATER."
2. HDPE PIPE SHALL BE BLUE OR HAVE CO-EXTRUDED BLUE STRIPES AND BE LABELED "POTABLE WATER"
3. ALL OTHER PIPE MATERIAL SHALL BE IDENTIFIED WITH BLUE PAINT OR AN ADHESIVE-BACKED TAPE.
4. THERE SHALL BE A MINIMUM OF THREE CONTINUOUS COLORED STRIPES OR TAPES ALONG THE PIPE (LOCATED AT 10:00, 12:00, AND 2:00) EACH A MINIMUM OF 2 INCHES WIDE.
5. THERE SHALL BE A BLUE TRACER WIRE INSTALLED WITH ALL NON-METALLIC PIPES, NO EXCEPTIONS.

Revision Date:
10/23/18



Gainesville Regional Utilities
Potable Water Construction Details

WATER MAIN PIPE IDENTIFICATION

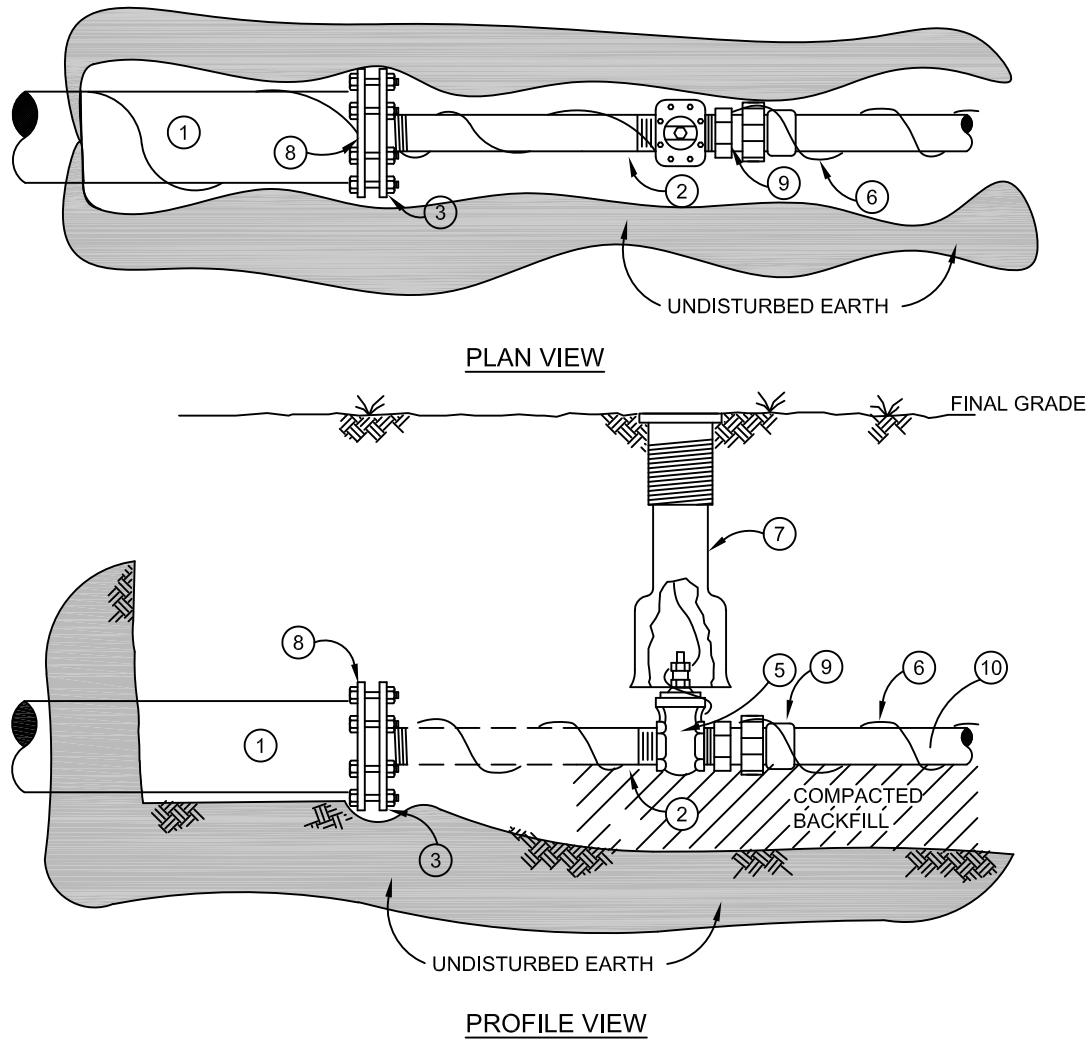

MATERIALS

ITEM	DESCRIPTION	
1	4", 6", 8", 12"	PIPE, D.I. OR PVC (DR-18)
2	2" x 6" L	LOW LEAD BRASS NIPPLE (INTO VALVE)
3	MJ x 2" FIP	TAPPED CAP, D.I.
5	2"	GATE VALVE, SQUARE NUT, RESILIENT WEDGE
6		TRACER WIRE, COPPER, INSULATED BLUE, #10 AWG
7		VALVE BOX
8		MEGA LUG
9	2" MPT X COMP.	BRASS GRIP JOINT COUPLING FORD CATALOG #C84-77-G-NL OR APPROVED EQUAL
10	2"	PE TUBING, BLUE, SDR-9,CTS

Revision Date:
11/9/2018



Gainesville Regional Utilities
Potable Water Construction Details

WATER MAINS REDUCTION OF LINE SIZE

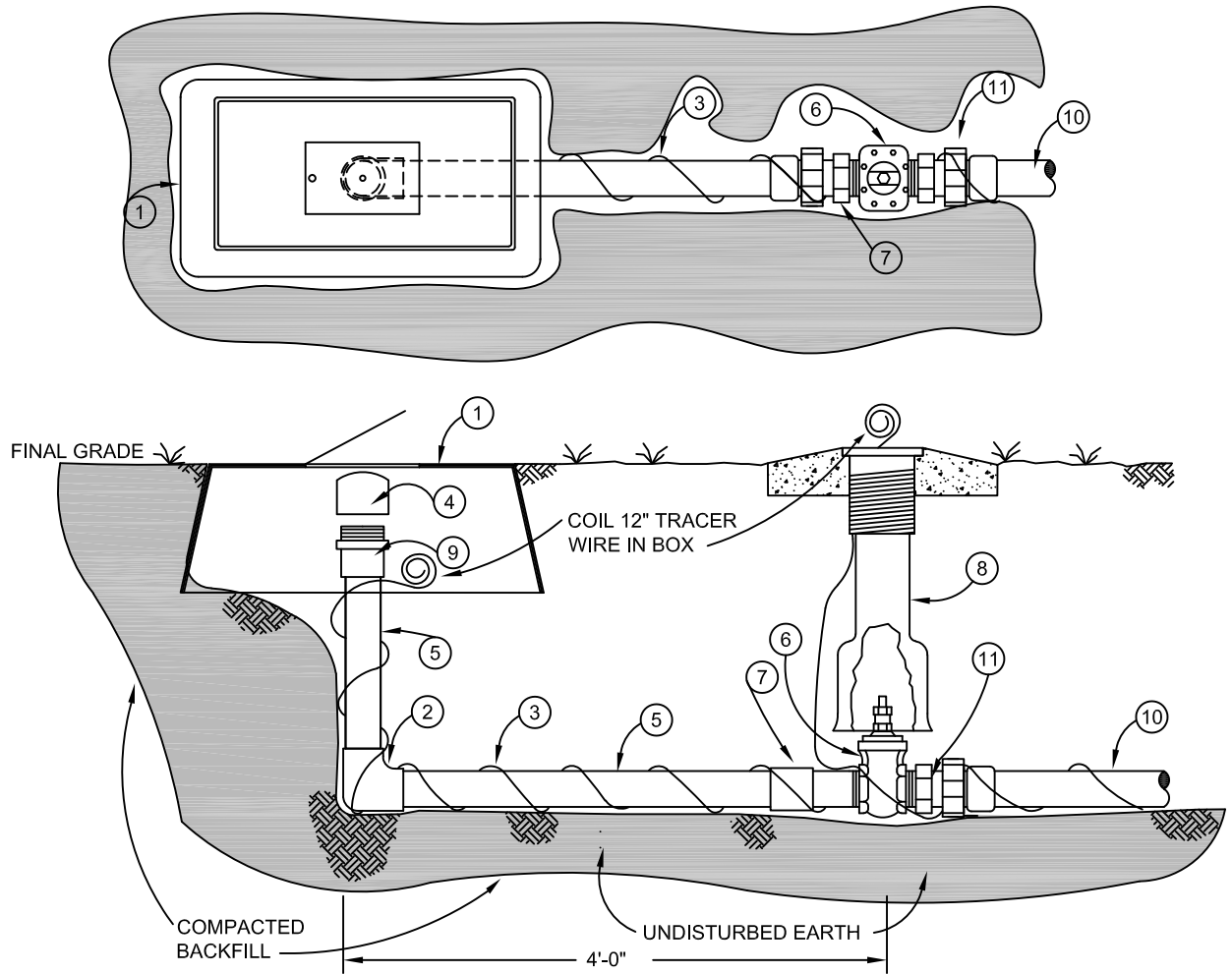

MATERIALS	
ITEM	DESCRIPTION
1	METER BOX
2	2" PVC 90° BEND
3	TRACER WIRE, COPPER, BLUE INSULATED #10 AWG
4	2" PVC SCREW ON CAP
5	2" PVC PIPE
6	2" GATE VALVE, SQUARE NUT, RESILIENT WEDGE
7	2" SCH 80 PVC NIPPLE & 2" SCH 40 PVC COUPLING
8	VALVE BOX, CAST IRON
9	2" SCH 40 PVC MALE ADAPTER WITH SCREW ON CAP
10	2" PE TUBING BLUE SDR-9, CTS
11	2" BRASS GRIP JOINT COUPLING FORD C84-77-G-NL

Revision Date:		Gainesville Regional Utilities Potable Water Construction Details
12/11/18		2" PVC BLOW-OFF ASSEMBLY

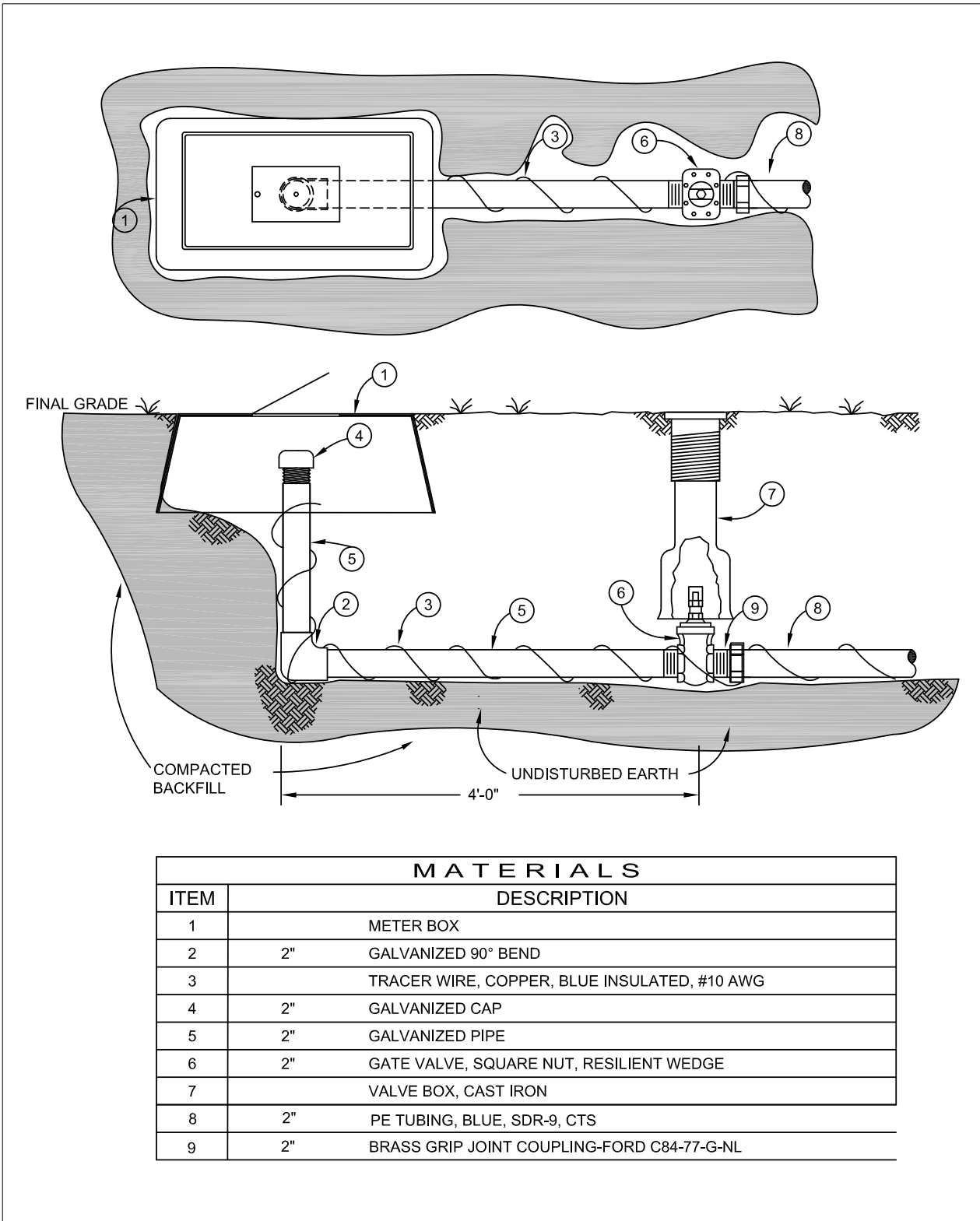

Revision Date:		Gainesville Regional Utilities Potable Water Construction Details
10/19/2018		2" GALVANIZED PIPE BLOW-OFF ASSEMBLY

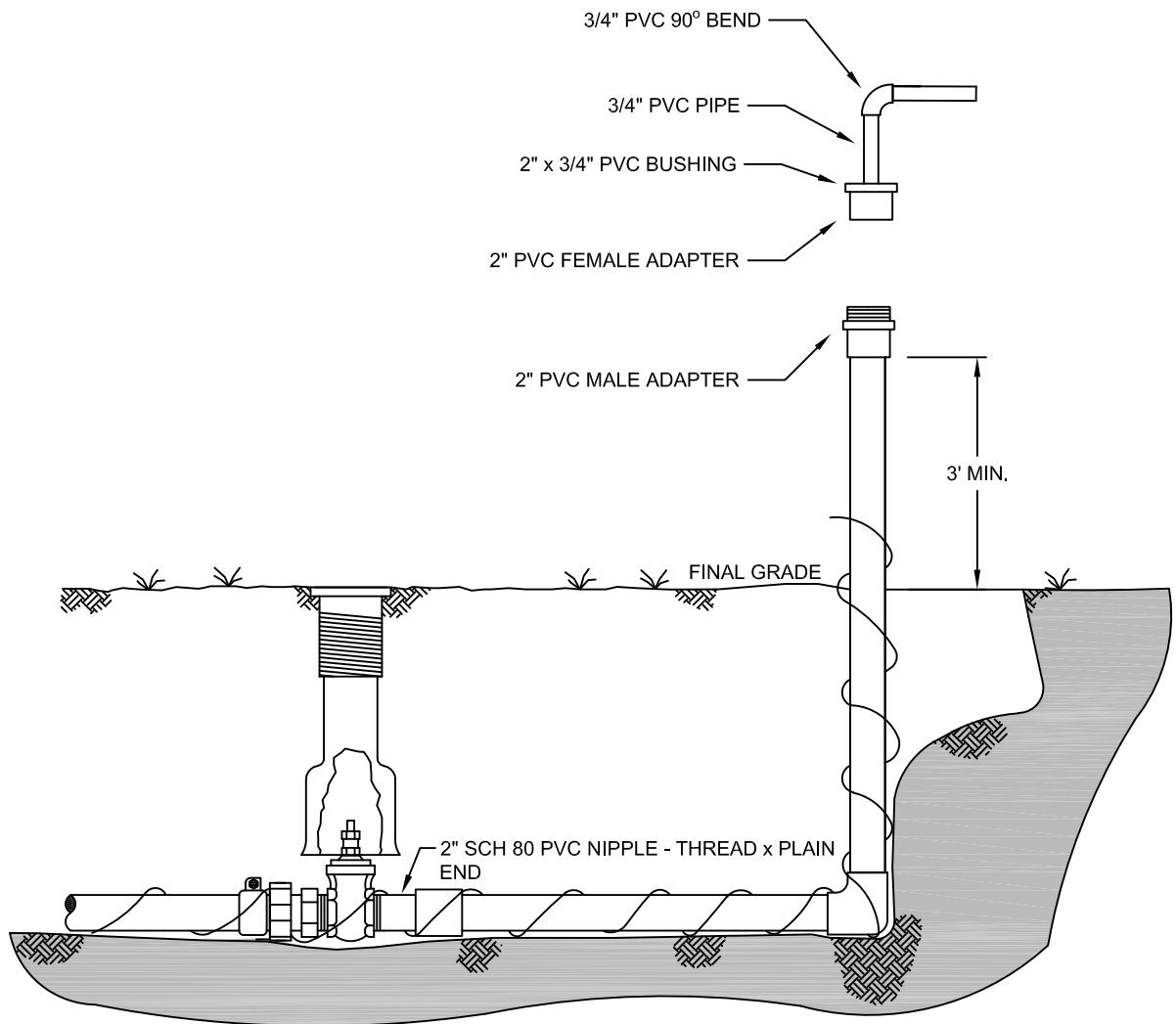

NOTE: SAMPLES WILL NOT BE COLLECTED UNDER UNSAFE CONDITIONS, INCLUDING SAMPLE POINTS BELOW GRADE, UNSTABLE SOIL, POOLED WATER GREATER THAN AN INCH DEPTH. SAMPLES WILL NOT BE COLLECTED UNDER RAIN OR MIST CONDITIONS. HOSE CONNECTIONS ARE NOT ALLOWED.

Revision Date: 12/10/18		Gainesville Regional Utilities Potable Water Construction Details SAMPLE POINT ASSEMBLY
----------------------------	---	--

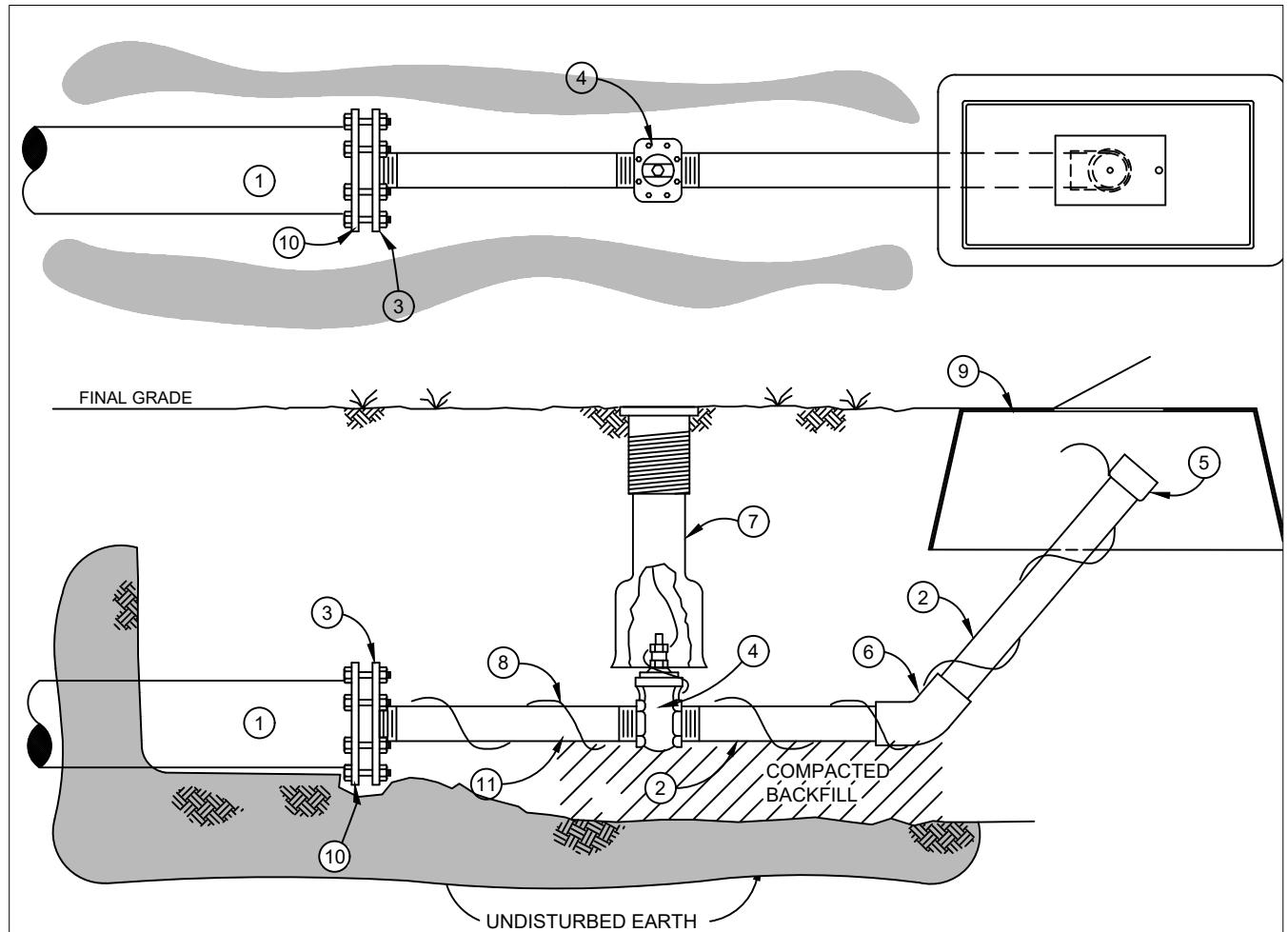

MATERIALS

ITEM	DESCRIPTION	
1	6" or 8"	WATER MAIN SIZE
2	3"	GALVANIZED PIPE
3	6" X 3" OR 8" X 3"	TAPPED CAP DUCTILE IRON
4	3"	GATE VALVE, SQUARE NUT, RESILIENT WEDGE
5	3"	GALV. CAP
6	3"	GALV. 45° BEND
7		VALVE BOX, CAST IRON
8		TRACER WIRE, COPPER, BLUE INSULATED, #10 AWG
9		METER BOX
10		EBAA MEGALUG, MECHANICALLY RESTRAINED GLAND
11		3" LOW LEAD BRASS NIPPLE

Revision Date:		Gainesville Regional Utilities
10/22/2018		Potable Water Construction Details
3" BLOW-OFF ASSEMBLY FOR 6" 8" WM		

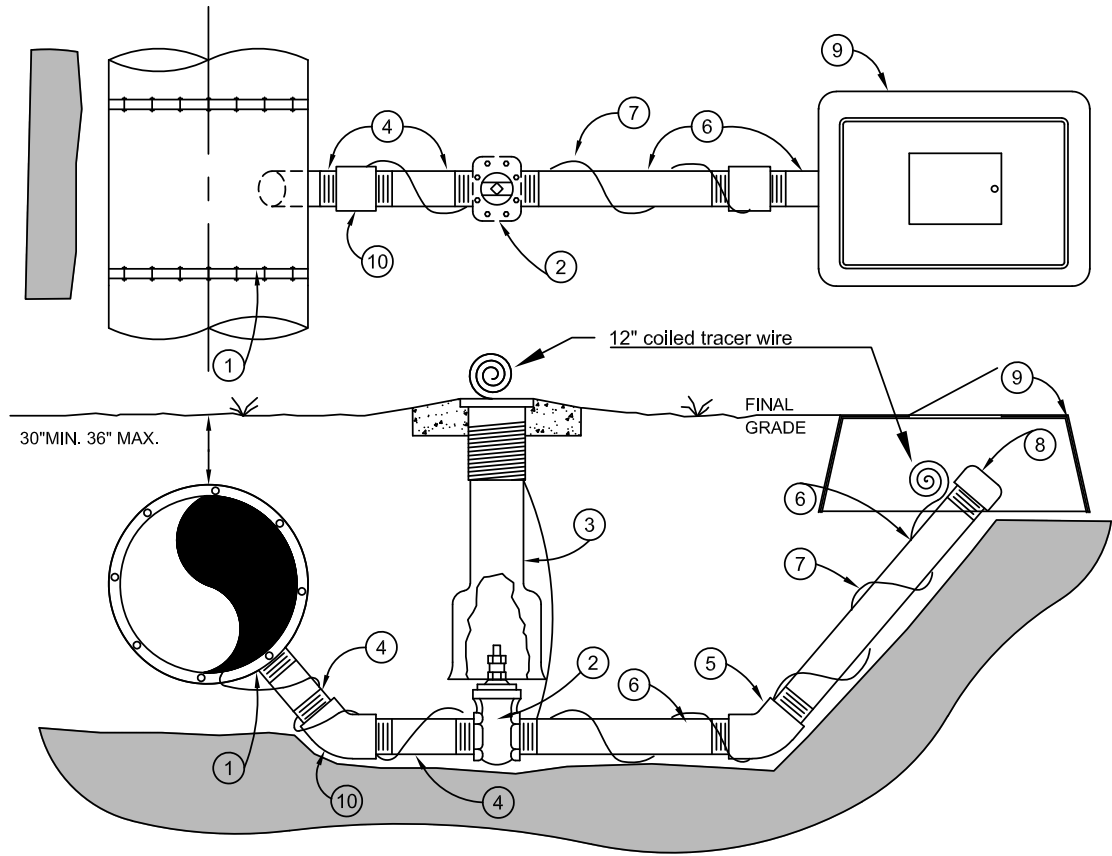

M A T E R I A L S

ITEM	DESCRIPTION	
1	6" or 8" X 3"	MJ TAPPED TEE (W/ EBAA MEGALUG RESTRAINT)
2	3"	VALVE, GATE, SQUARE NUT, RESILIENT WEDGE
3		VALVE BOX, C.I.
4	3" X 4" L	BRASS NIPPLE
5	3" X 45°	BEND, GALV.
6	3" X VARIES	PIPE, GALV.
7		TRACER WIRE, BLUE
8	3"	GALV. CAP
9		METER BOX
10	3" X 45°	BEND, BRASS

1. TRACER WIRE SHALL BE SPIRALED AROUND THE PIPE, TAPED EVERY TEN FEET AND CONNECTED TO THE MAIN LINE TRACER WIRE. CONNECT USING TRACER-LOCK PART# TL-LUG-55 CONNECTORS.

Revision Date: 2/6/2019		Gainesville Regional Utilities Potable Water Construction Details 3" BLOW-OFF ASSEMBLY, PERPENDICULAR TO MAIN
----------------------------	---	---

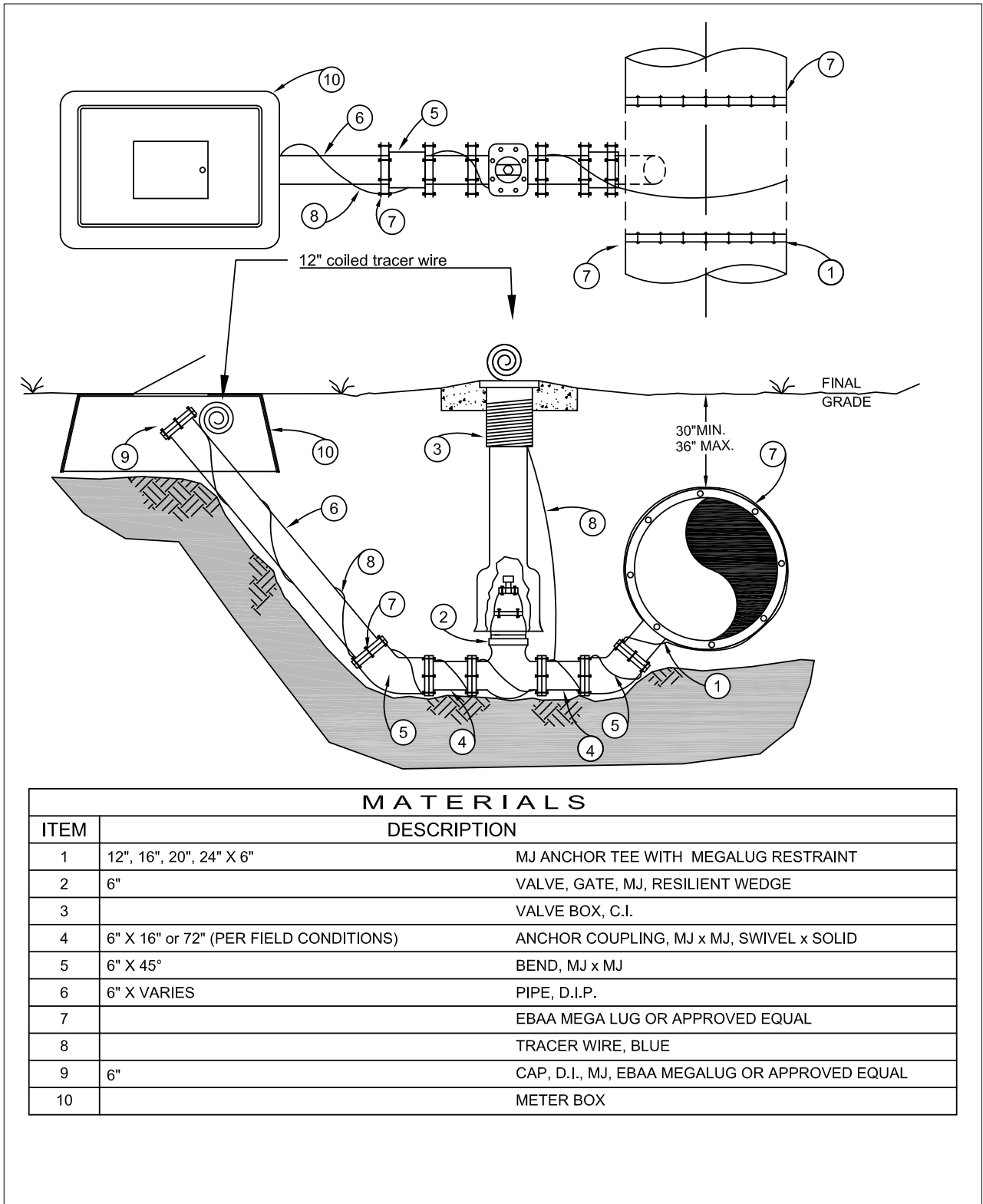

MATERIALS

ITEM	DESCRIPTION	
1	12", 16", 20", 24" X 6"	MJ ANCHOR TEE WITH MEGALUG RESTRAINT
2	6"	VALVE, GATE, MJ, RESILIENT WEDGE
3		VALVE BOX, C.I.
4	6" X 16" or 72" (PER FIELD CONDITIONS)	ANCHOR COUPLING, MJ x MJ, SWIVEL x SOLID
5	6" X 45°	BEND, MJ x MJ
6	6" X VARIES	PIPE, D.I.P.
7		EBAA MEGA LUG OR APPROVED EQUAL
8		TRACER WIRE, BLUE
9	6"	CAP, D.I., MJ, EBAA MEGALUG OR APPROVED EQUAL
10		METER BOX

Revision Date: 01/30/2019		Gainesville Regional Utilities Potable Water Construction Details 6" BLOW-OFF ASSEMBLY
------------------------------	--	--

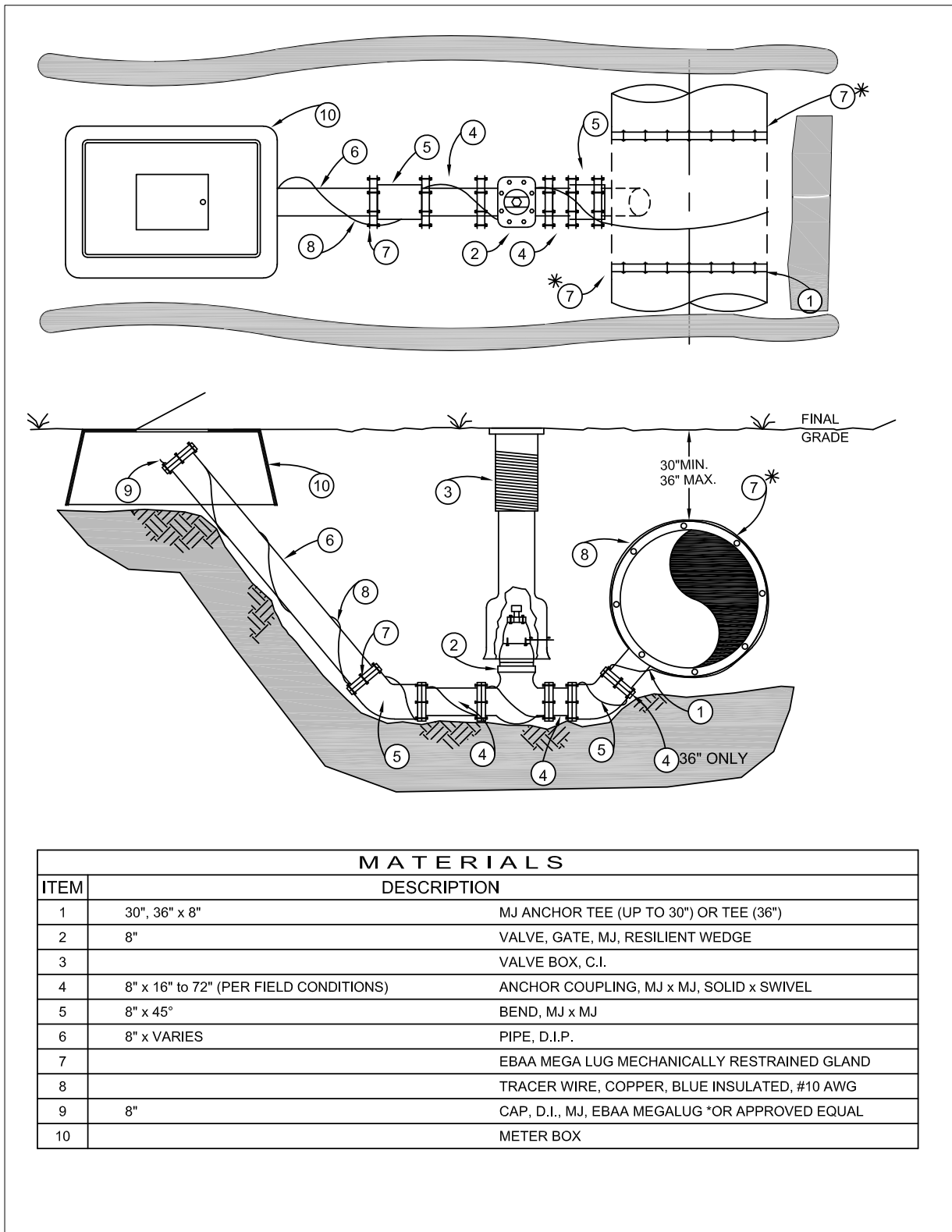

MATERIALS

ITEM	DESCRIPTION
1	30", 36" x 8" MJ ANCHOR TEE (UP TO 30") OR TEE (36")
2	8" VALVE, GATE, MJ, RESILIENT WEDGE
3	VALVE BOX, C.I.
4	8" x 16" to 72" (PER FIELD CONDITIONS) ANCHOR COUPLING, MJ x MJ, SOLID x SWIVEL
5	8" x 45° BEND, MJ x MJ
6	8" x VARIES PIPE, D.I.P.
7	EBAA MEGA LUG MECHANICALLY RESTRAINED GLAND
8	TRACER WIRE, COPPER, BLUE INSULATED, #10 AWG
9	8" CAP, D.I., MJ, EBAA MEGALUG *OR APPROVED EQUAL
10	METER BOX

Revision Date: 12/14/18		Gainesville Regional Utilities Potable Water Construction Details 8" BLOW-OFF ASSEMBLY
----------------------------	---	--

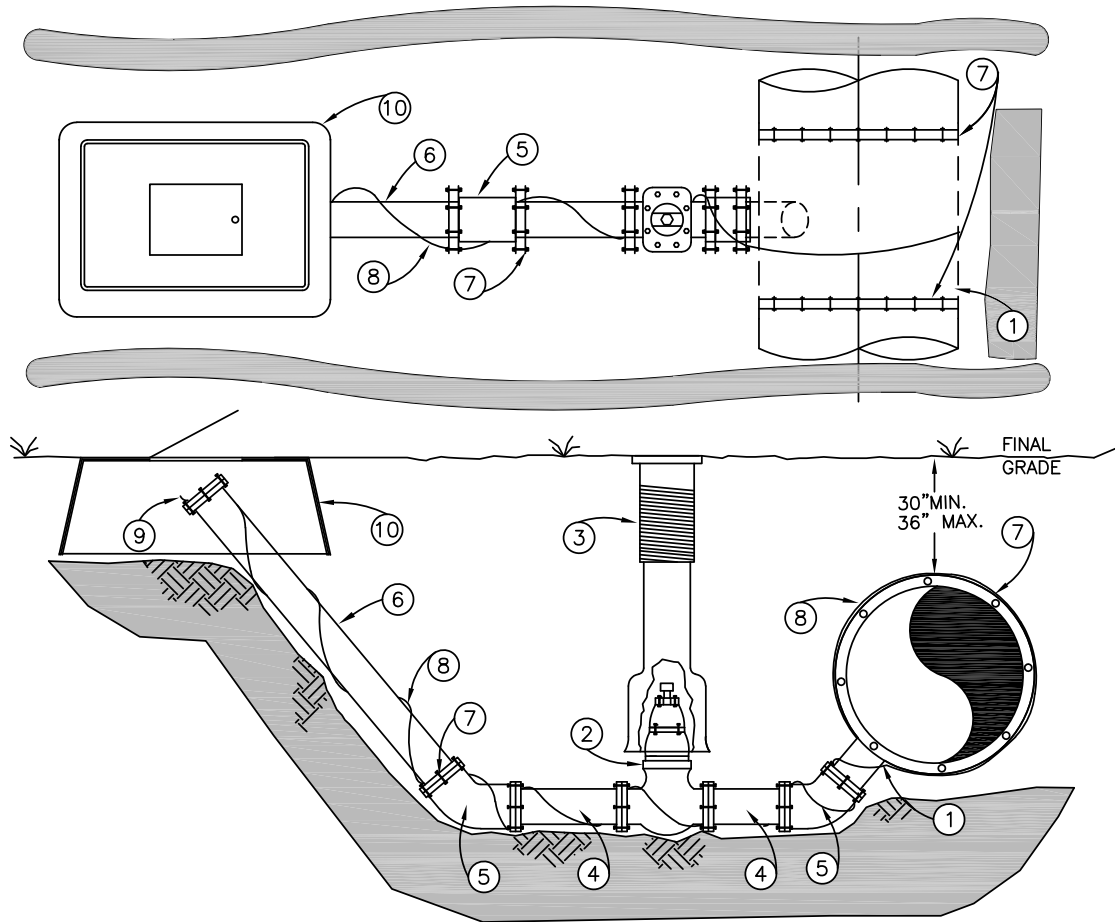

M A T E R I A L S

ITEM	DESCRIPTION	
1	36" x 12"	MJ TEE WITH EBAA MEGALUG (OR APPROVED EQUAL) RESTRAINT
2	12"	VALVE, GATE, MJ, RESILIENT WEDGE
3		VALVE BOX, C.I.
4	12" x 16" TO 72" (PER FIELD CONDITIONS)	ANCHOR COUPLING, MJ X MJ, SOLID X SWIVEL
5	12" x 45'	BEND, MJ X MJ
6	12" x VARIES	PIPE, D.I.P.
7		EBAA MEGALUG (OR APPROVED EQUAL) MECHANICALLY RESTRAINED GLAND
8		TRACER WIRE, COPPER, BLUE INSULATED, #10 AWG
9	12"	CAP, D.I., MJ, EBAA MEGALUG (OR APPROVED EQUAL)
10		METER BOX

Revision Date:
12/17/18



Gainesville Regional Utilities
Potable Water Construction Details

12" BLOW-OFF ASSEMBLY

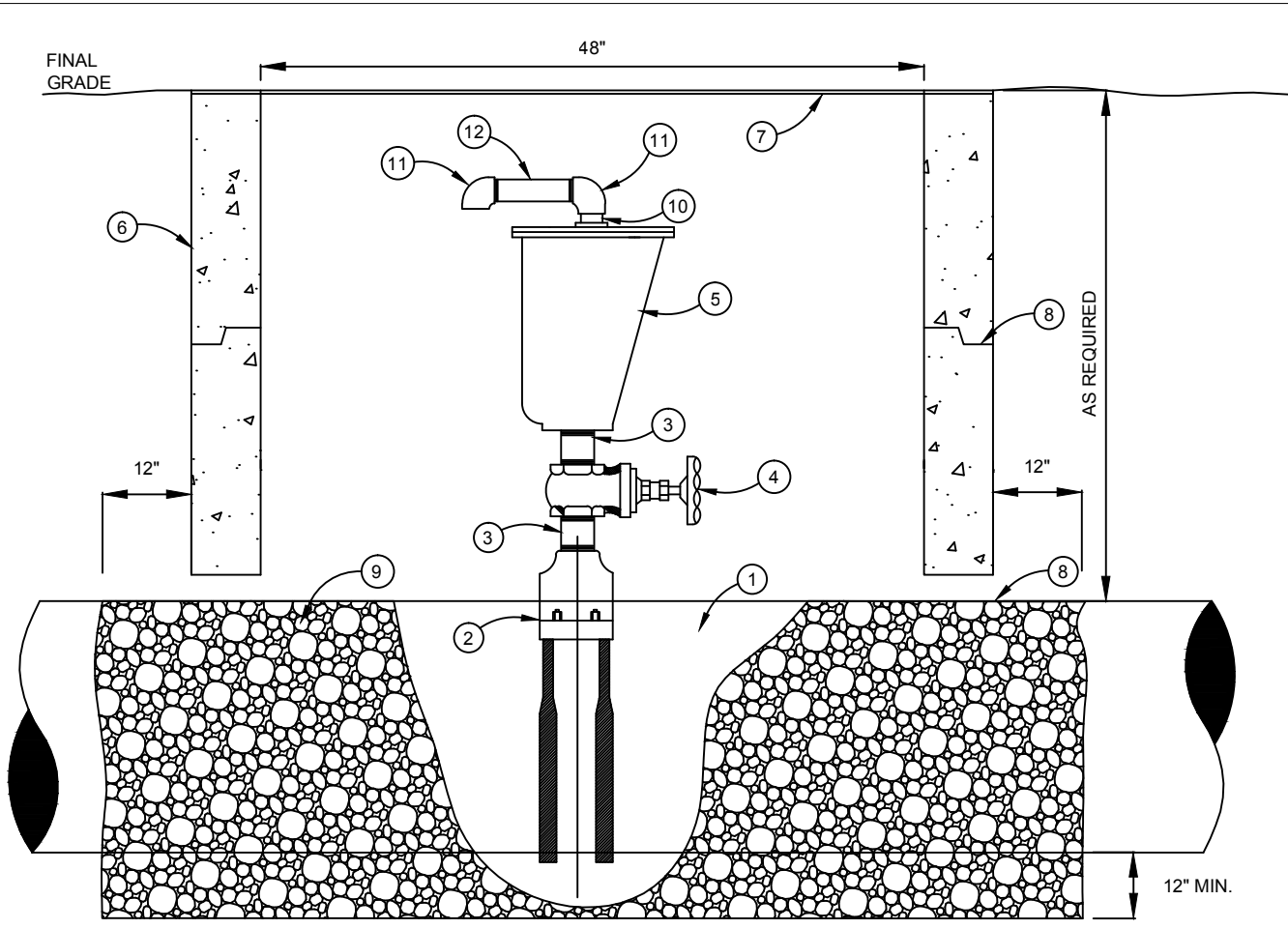

MATERIALS		
ITEM	DESCRIPTION	
1	6"-36"	WATER MAIN *
2	2" (TAP)	SERVICE SADDLE 2" NPT *
3	2" x 4"	LOW LEAD BRASS NIPPLE OUTLET
4	2"	LOW LEAD BRASS GATE VALVE HANDWHEEL
5		AIR RELEASE VALVE
6	4' x 4'	CONCRETE VAULT (DO NOT BEAR ON PIPE)
7	4' x 4'	GALVANIZED STEEL PLATE
8		MANHOLE JOINT SEALANT
9		GRAVEL (No. 57 STONE)
10	3/4"	GSP NIPPLE
11	3/4"	90° ELBOW (G.S.P.)
12	3/4"	GSP W/ THREADED ENDS

* 30" AND 36" WATERMAIN REQUIRES 3" AIR RELEASE VALVE.

<p>Revision Date: 08/22/2016</p>		<p>Gainesville Regional Utilities Potable Water Construction Details AIR RELEASE VALVE CONSTRUCTION</p>
--------------------------------------	--	--

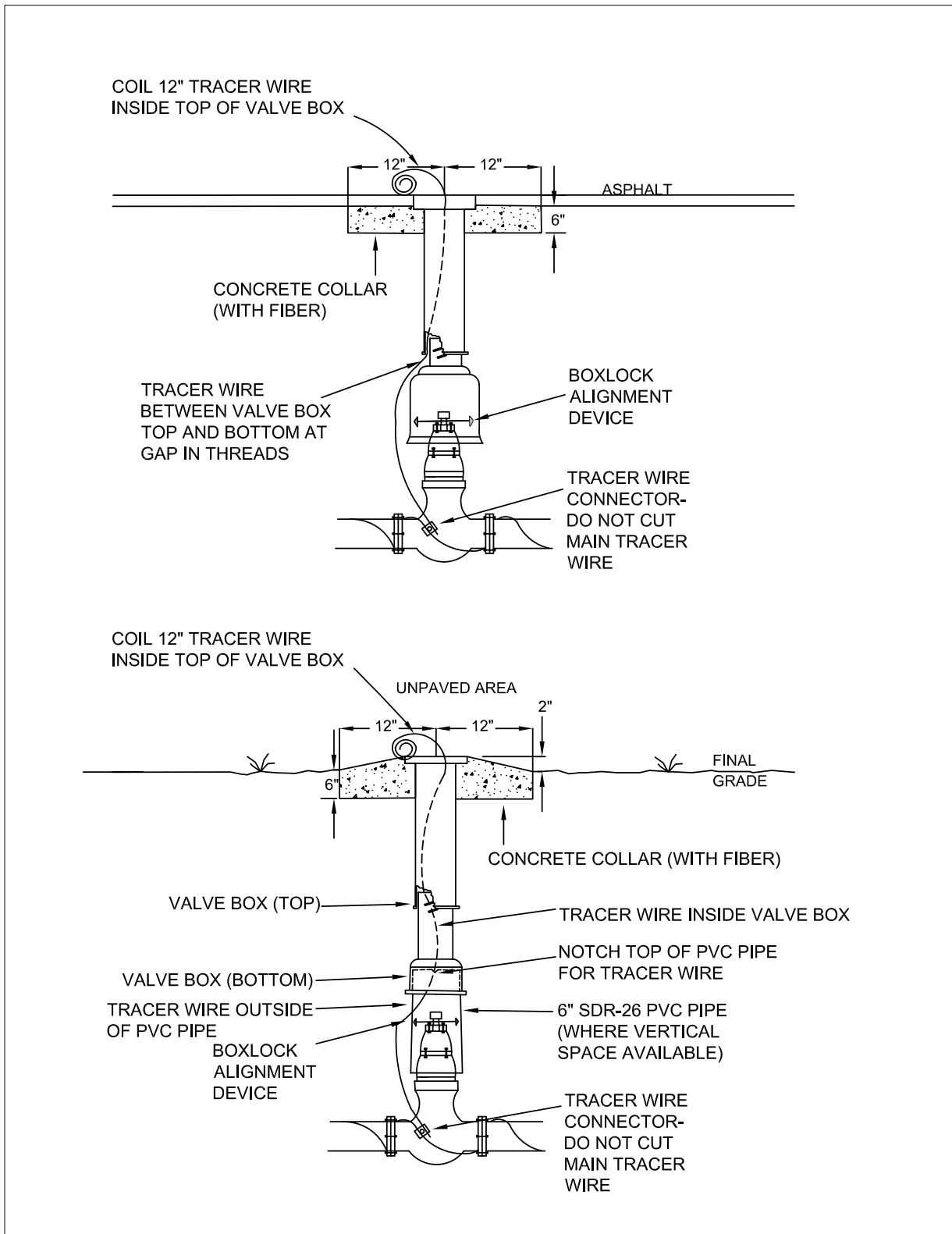

<p>Revision Date: 5/02/2019</p>		<p>Gainesville Regional Utilities Potable Water Construction Details</p> <p>VALVE BOX</p>
-------------------------------------	---	--

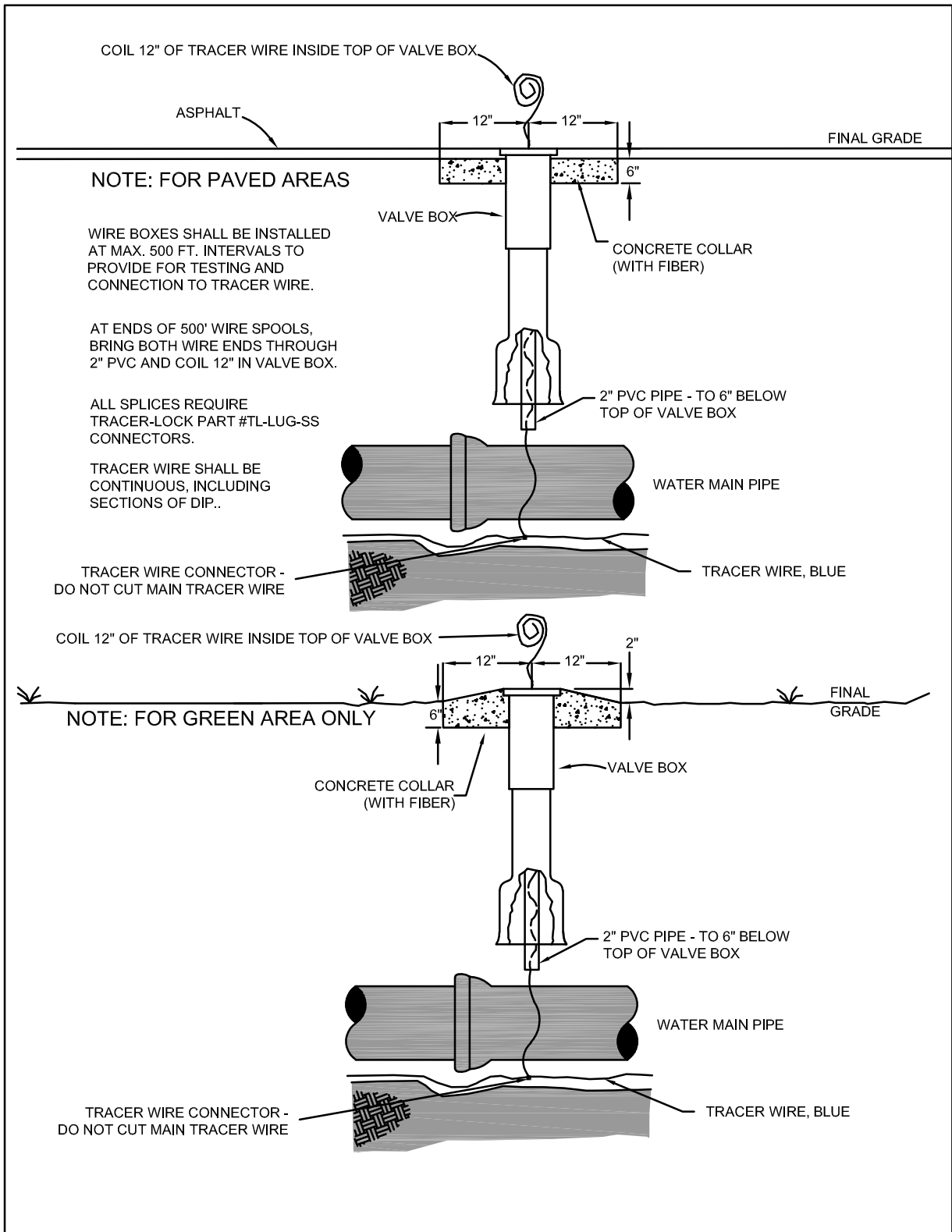

<p>Revision Date: 3/26/2019</p>		<p>Gainesville Regional Utilities Potable Water Construction Details TRACER WIRE BOX - WATER MAIN</p>
-------------------------------------	---	--

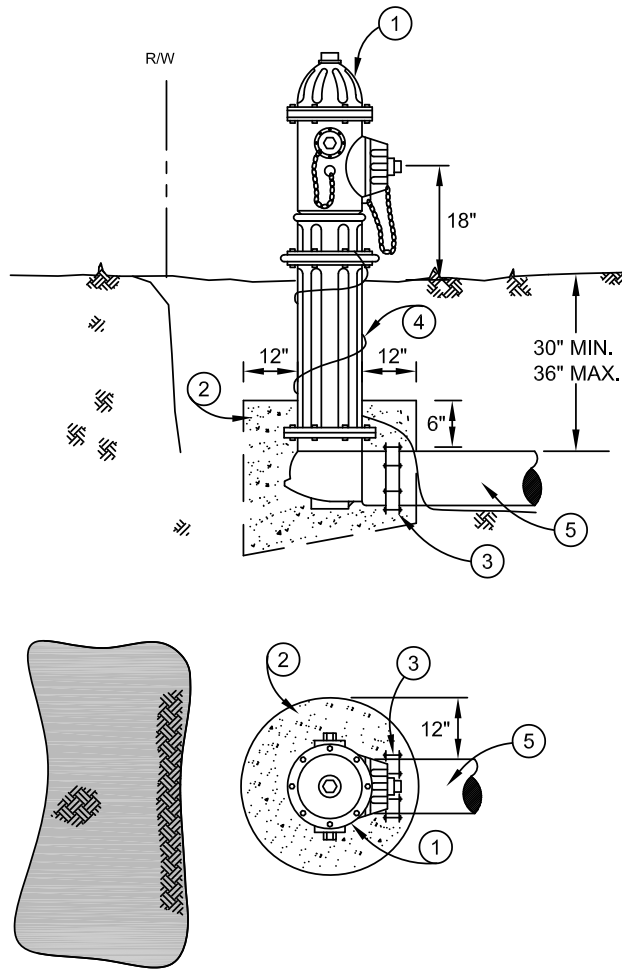

MATERIALS	
ITEM	DESCRIPTION
1	FIRE HYDRANT
2	GRAVEL DRAIN BED (No. 57 STONE)
3	MEGALUG RESTRAINT (EBAA OR APPROVED EQUAL)
4	TRACER WIRE, COPPER, BLUE INSULATED, #10 AWG
5	PIPE, D.I.

NOTES:

1. RESTRAIN MINIMUM 58' OF PIPE.

Revision Date:
12/10/18



Gainesville Regional Utilities
Potable Water Construction Details

FIRE HYDRANT - DEAD END MAIN

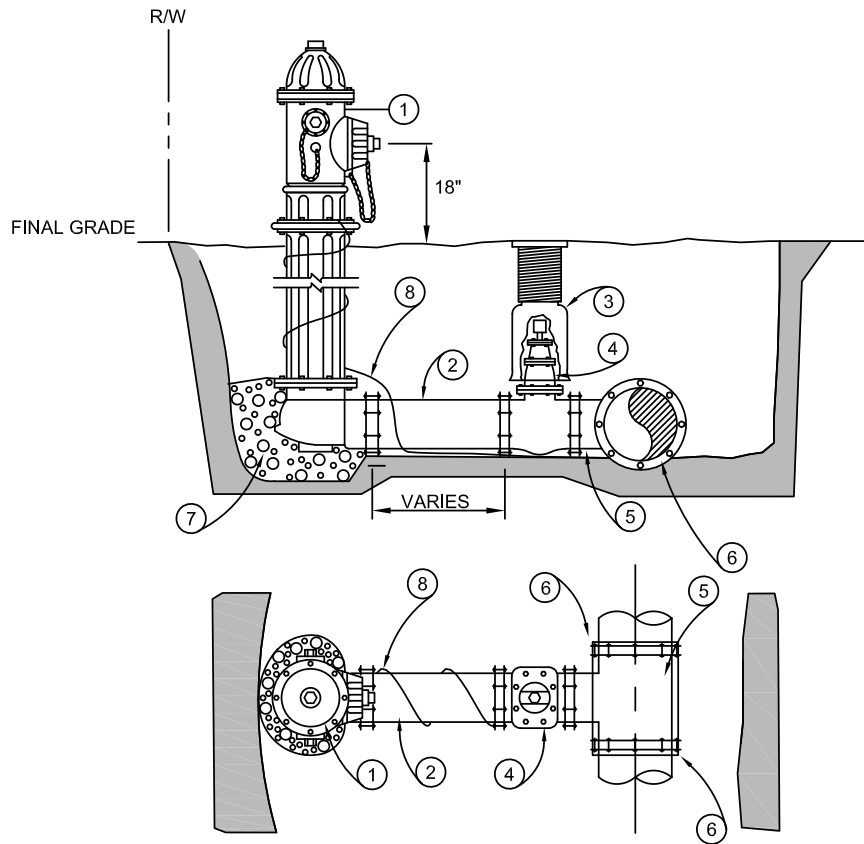

FIRE HYDRANT PERPENDICULAR TO THE MAIN

MATERIALS

ITEM	DESCRIPTION
1	FIRE HYDRANT
2	ANCHOR COUPLING (RESTRAINED DIP FOR LONGER LENGTHS)
3	VALVE BOX, C.I.
4	GATE VALVE
5	ANCHOR TEE
6	MEGALUG - EBAA OR APPROVED EQUAL
7	GRAVEL DRAIN BED
8	TRACER WIRE, COPPER, BLUE INSULATED, #10 AWG

Revision Date:
12/10/2018



Gainesville Regional Utilities
Potable Water Construction Details

FIRE HYDRANT PERPENDICULAR TO THE MAIN

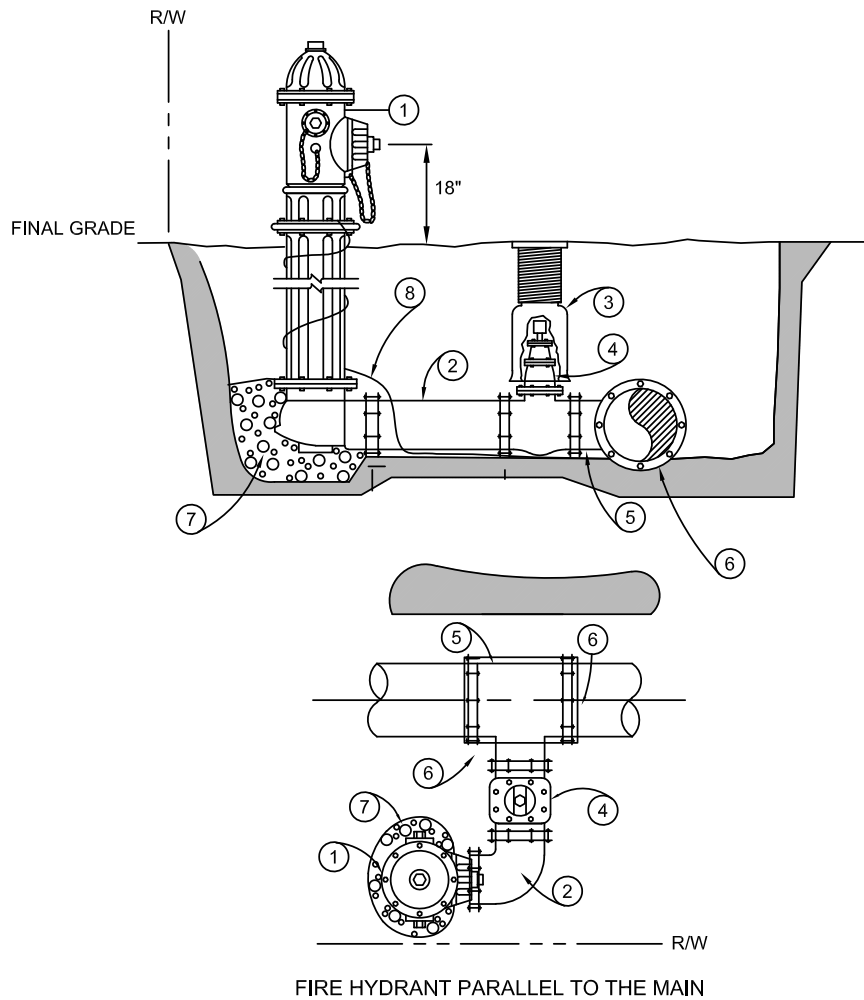

MATERIALS	
ITEM	DESCRIPTION
1	FIRE HYDRANT
2	ANCHOR 90° BEND, M.J.
3	VALVE BOX, C.I.
4	GATE VALVE
5	ANCHOR TEE
6	MEGALUG - EBAA OR APPROVED EQUAL
7	GRAVEL DRAIN BED
8	TRACER WIRE, COPPER, BLUE INSULATED, #10 AWG

<p>Revision Date: 12/10/2018</p>		<p>Gainesville Regional Utilities Potable Water Construction Details PARALLEL TO THE MAIN</p>
--------------------------------------	---	--

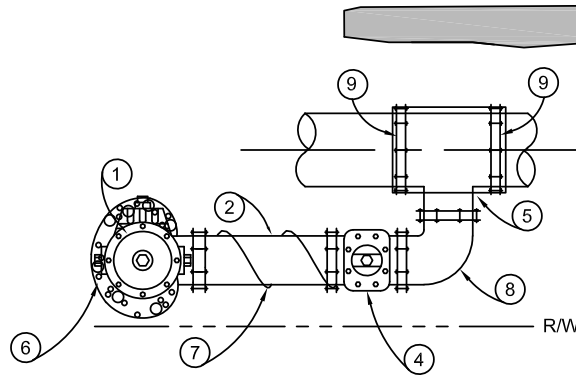
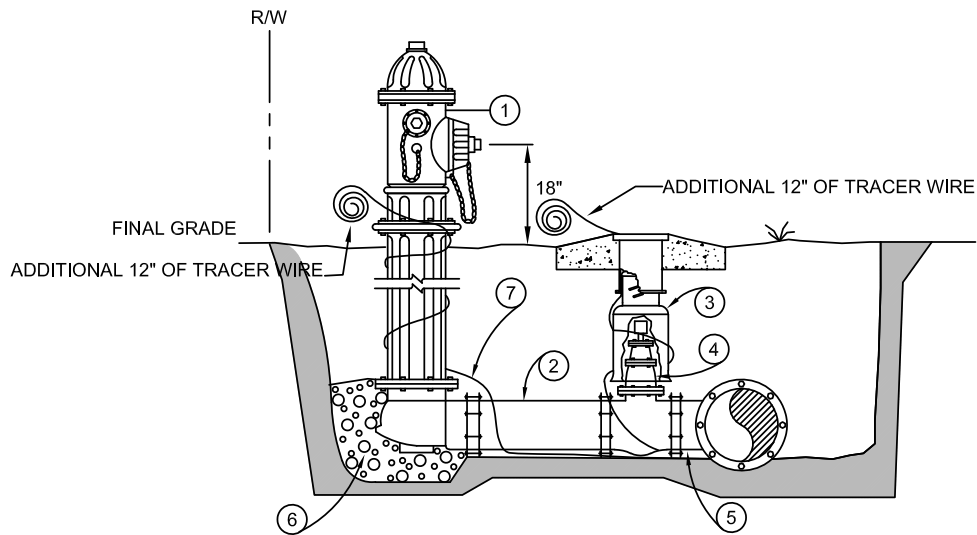

FIRE HYDRANT PARALLEL CLOSE TO THE MAIN

MATERIALS

ITEM	DESCRIPTION
1	FIRE HYDRANT
2	ANCHOR COUPLING, M.J x M.J., SOLID x SWIVEL
3	VALVE BOX, C.I.
4	GATE VALVE, M.J. x M.J.
5	STANDARD TEE, D.I., M.J.
6	GRAVEL DRAIN BED
7	TRACER WIRE, BLUE INSULATED
8	ANCHOR 90° BEND, M.J.,D.I.
9	MEGALUG (EBAA OR APPROVED EQUAL)

NOTES:

1. TRACER WIRE SHALL BE SPIRALED AROUND THE PIPE, TAPED EVERY TEN FEET AND CONNECTED TO THE MAIN LINE TRACER WIRE. CONNECT USING TRACER-LOCK PART # TL-LUG-55 CONNECTORS.

Revision Date:
01/10/2019



Gainesville Regional Utilities
Potable Water Construction Details

FIRE HYDRANT PARALLEL CLOSE TO THE MAIN

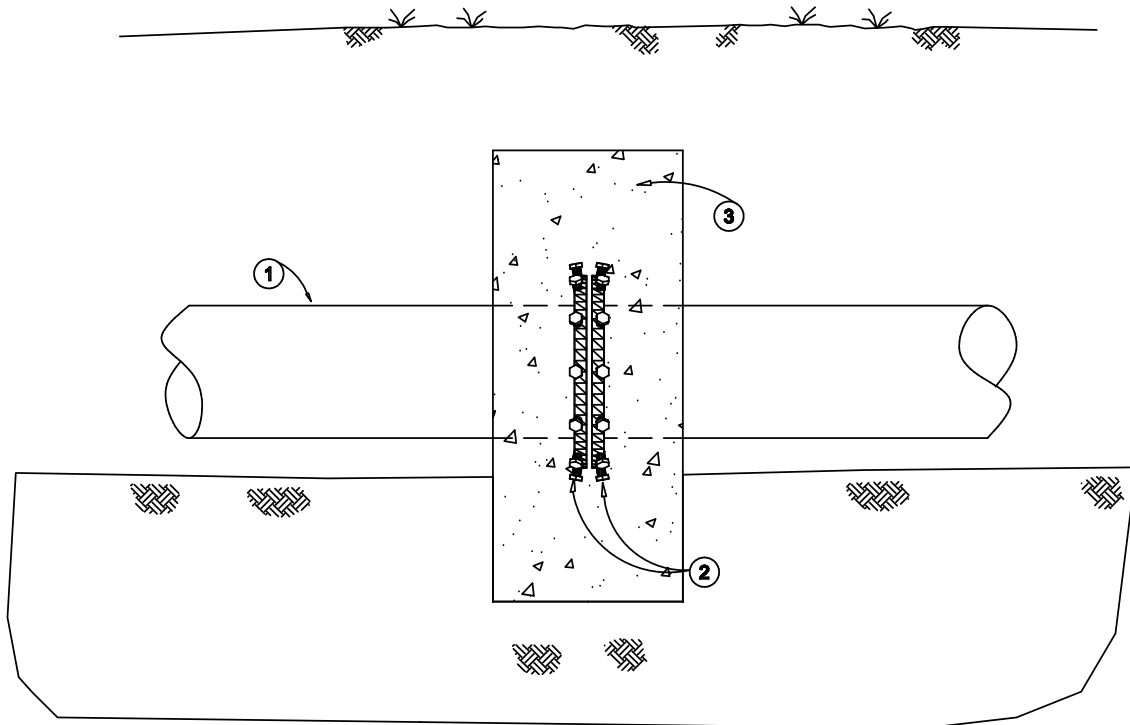

MATERIALS

ITEM	DESCRIPTION
1	PIPE, D.I.
2	EBAA RESTRAINT COLLAR
3	CONCRETE THRUST BLOCK ("DEAD MAN"), 2500 PSI

NOTES:

1. SEE W - 2.2 FOR BEARING AREA REQUIRED.
2. TWO EBAA RESTRAINT COLLARS REQUIRED, ONE FACING EACH WAY.
3. A NON-POROUS MATERIAL SUCH AS 8-MIL VISQUEEN OR 15 LB. FELT SHALL BE PLACED BETWEEN THE CONCRETE AND THE COLLARS.
4. MECHANICAL RESTRAINT IS REQUIRED IN ALL CASES, UNLESS USE OF A THRUST BLOCK FOR AN EXISTING WATER MAIN IS APPROVED ON A CASE BY CASE BASIS IN WRITING BY GRU WATER & WASTEWATER ENGINEERING.

Revision Date:

1/10/19



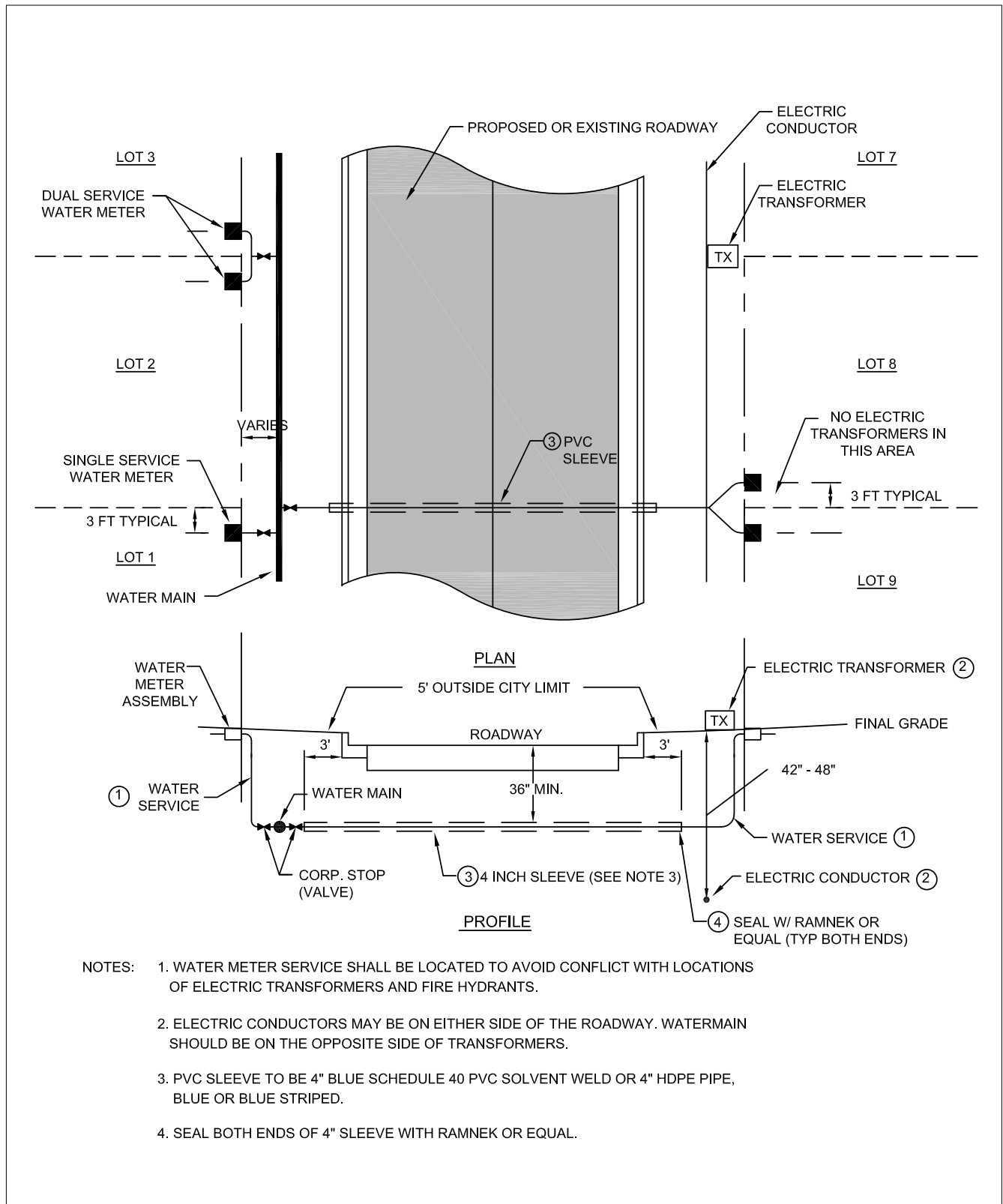

Gainesville Regional Utilities
Potable Water Construction Details

MID-SPAN "DEAD MAN" THRUST BLOCK

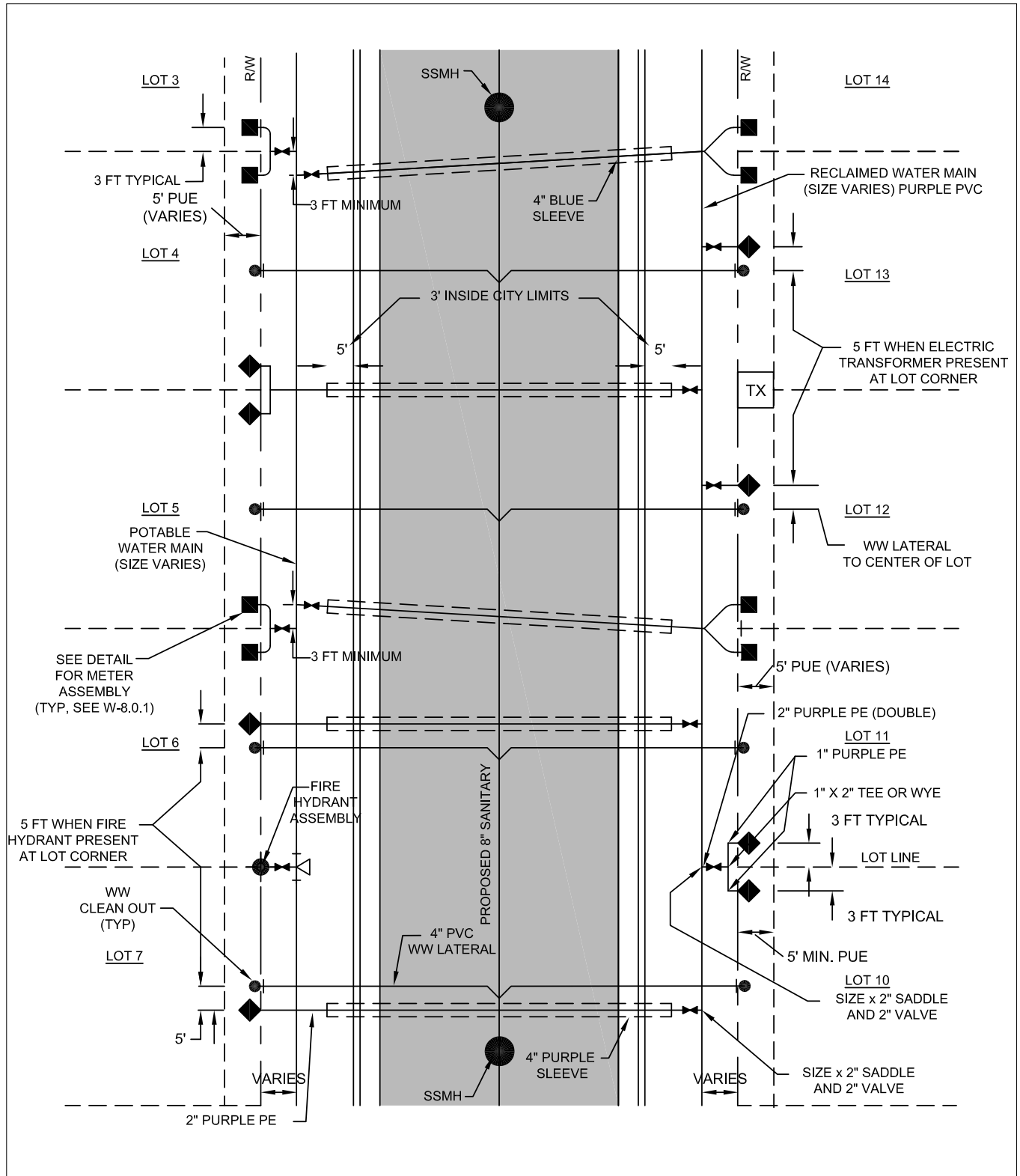

<p>Revision Date: 10/22/18</p>		<p align="center">Gainesville Regional Utilities Potable Water Construction Details</p> <hr/> <p align="center">SINGLE & DUAL WATER SERVICE</p>
------------------------------------	---	---



<p>Revision Date: 04/17/19</p>		<p align="center">Gainesville Regional Utilities Potable Water Construction Details WATER, WASTEWATER, AND RECLAIMED WATER FACILITY ALLOCATION IN RESIDENTIAL DEVELOPMENT</p>
------------------------------------	---	--

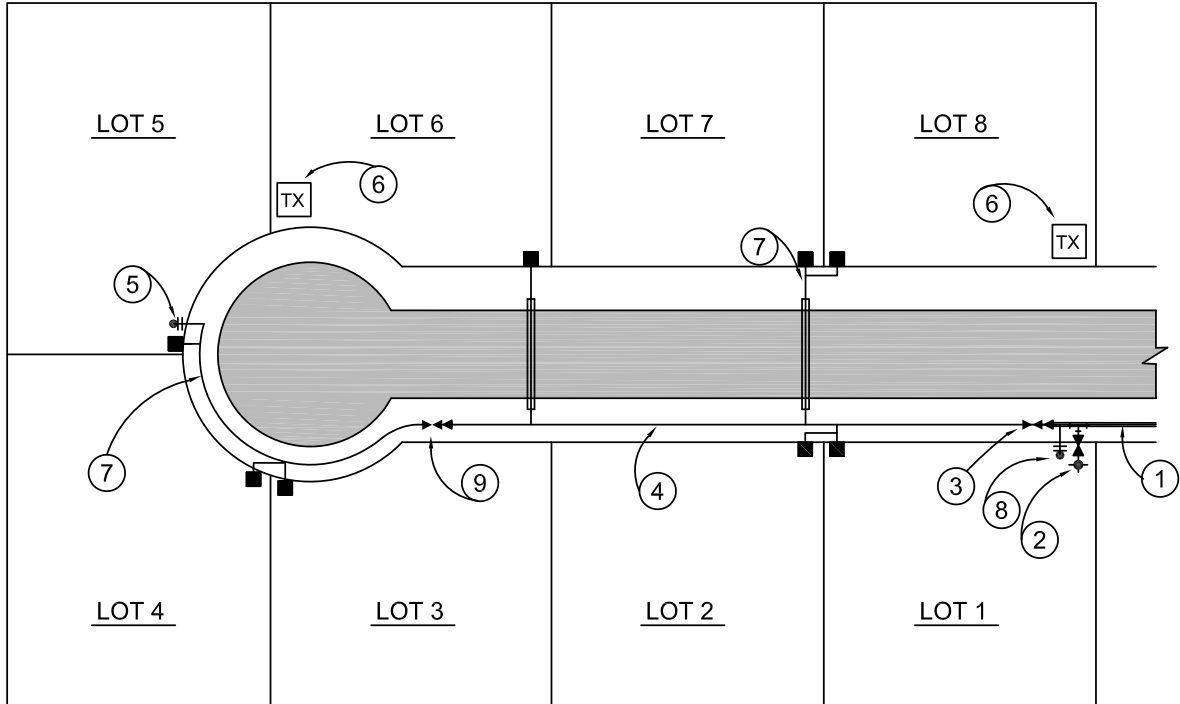

MATERIALS	
ITEM	DESCRIPTION
1	WATER MAIN (MIN. 6")
2	FIRE HYDRANT ASSEMBLY
3	REDUCER FITTING AND 4" GATE VALVE & BOX
4	4" DIP WATER MAIN
5	2" BLOW-OFF AND SAMPLE POINT
6	ELECTRIC TRANSFORMER
7	2" BLUE CTS PE SDR-9 WATER MAIN (MAX. 4 SERVICES)
8	3" BLOW-OFF AND SAMPLE POINT
9	4" X 2" TAPPED CAP, 2" BRASS NIPPLE, 2" GATE VALVE & BOX AND 2" BRASS GRIP JOINT COUPLING PER W-3.3

1. Tracer wire shall be continuous across DIP section of water main.

Revision Date: 02/18/19		Gainesville Regional Utilities Potable Water Construction Details DEAD END WATER MAIN CONSTRUCTION
----------------------------	---	--

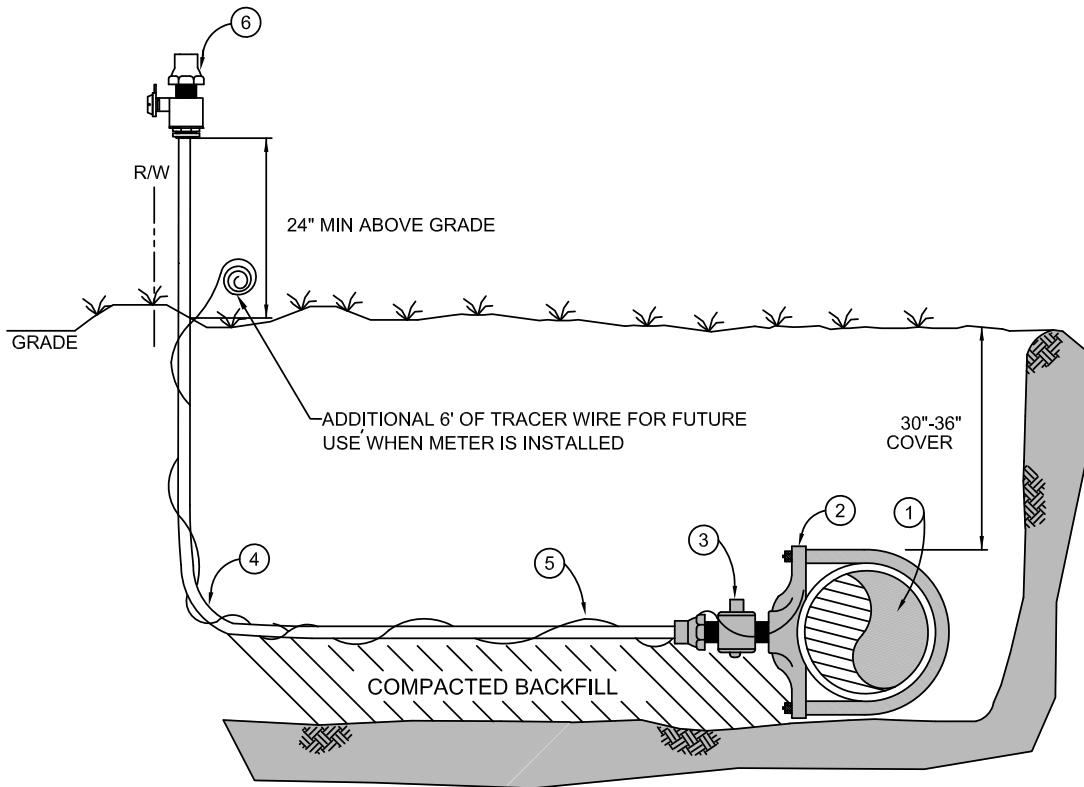

MATERIALS	
ITEM	DESCRIPTION
1	4", 6", 8", 12" WATER MAIN
2	4", 6", 8", 12" SERVICE SADDLE W/1" CC (TAPERED THREADS)
3	1"CC x1" COMP. CORPORATION STOP FOR PE TUBING (GRIP JOINT-FORD F1000-4-G-NL)
4	1" POLYETHYLENE TUBING, BLUE, SDR-9, CTS-MIN. 22.5" BEND RADIUS
5	TRACER WIRE, BLUE
6	5/8" x3/4" WATER METER YOKE VALVE (FORD B94-324W-G-NL)
	1" WATER METER YOKE VALVE (FORD B94-344W-G-NL)

- NOTES:**
- ALL FITTINGS FOR POLYETHYLENE TUBING ARE COMPRESSION TYPE (GRIP JOINT).
 - TRACER WIRE SHALL BE SPIRALED AROUND THE TUBING, TAPED EVERY TEN FEET AND CONNECTED TO THE MAIN LINE TRACER WIRE USING TRACER-LOCK PART # TL-LUG-SS CONNECTORS.
 - NO INSERTS (STIFFENERS) SHALL BE PLACED IN ENDS OF TUBING.
 - SEE W-8.0.1 FOR WATER METER ASSEMBLY INSTALLATION.
- FORD= FORD METER BOX COMPANY

Revision Date: 3/01/2018		Gainesville Regional Utilities Potable Water Construction Details POLYETHYLENE TUBING WATER SERVICE MAIN SIDE
-----------------------------	---	---

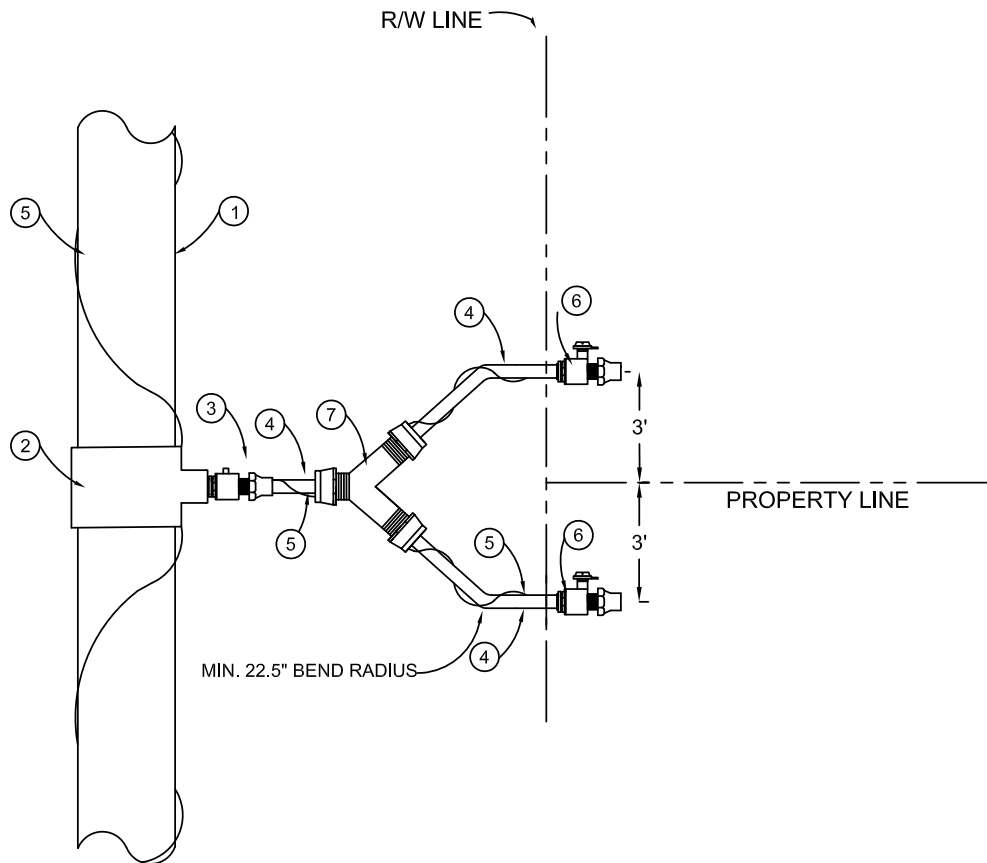

MATERIALS

ITEM	DESCRIPTION	
1	4", 6", 8", 12"	WATER MAIN
2	4", 6", 8", 12"	SERVICE SADDLE W/1" CC (TAPERED THREADS)
3	1"CC X1" COMP.	CORPORATION STOP FOR PE TUBING (GRIP JOINT)
4		POLYETHYLENE TUBING, BLUE, SDR-9,CTS
5		TRACER WIRE, BLUE, # 10 AWG
6	5/8" X 3/4"	WATER METER YOKE VALVE (FORD B94-324W-G-NL)
	1"	WATER METER YOKE VALVE (FORD B94-344W-G-NL)
7	1"	BRASS GRIP JOINT TEE OR WYE (FORD Y44-274-G-NL)

NOTES: 1. ALL FITTINGS FOR POLYETHYLENE TUBING ARE COMPRESSION TYPE (GRIP JOINT).

2. TRACER WIRE SHALL BE SPIRALED AROUND THE TUBING, TAPED EVERY TEN FEET AND CONNECTED TO THE MAIN LINE TRACER WIRE AND AT WYE USING TRACER-LOCK PART#TL-LUG-SS CONNECTORS.

3. NO INSERTS (STIFFENERS) SHALL BE PLACED INTO ENDS OF TUBING.

4. SEE W-B.0.1 FOR WATER METER ASSEMBLY INSTALLATION.

FORD= FORD METER BOX COMPANY

Revision Date:

12/05/2018



Gainesville Regional Utilities
Potable Water Construction Details

DOUBLE 1 INCH POLYETHYLENE WATER SERVICE

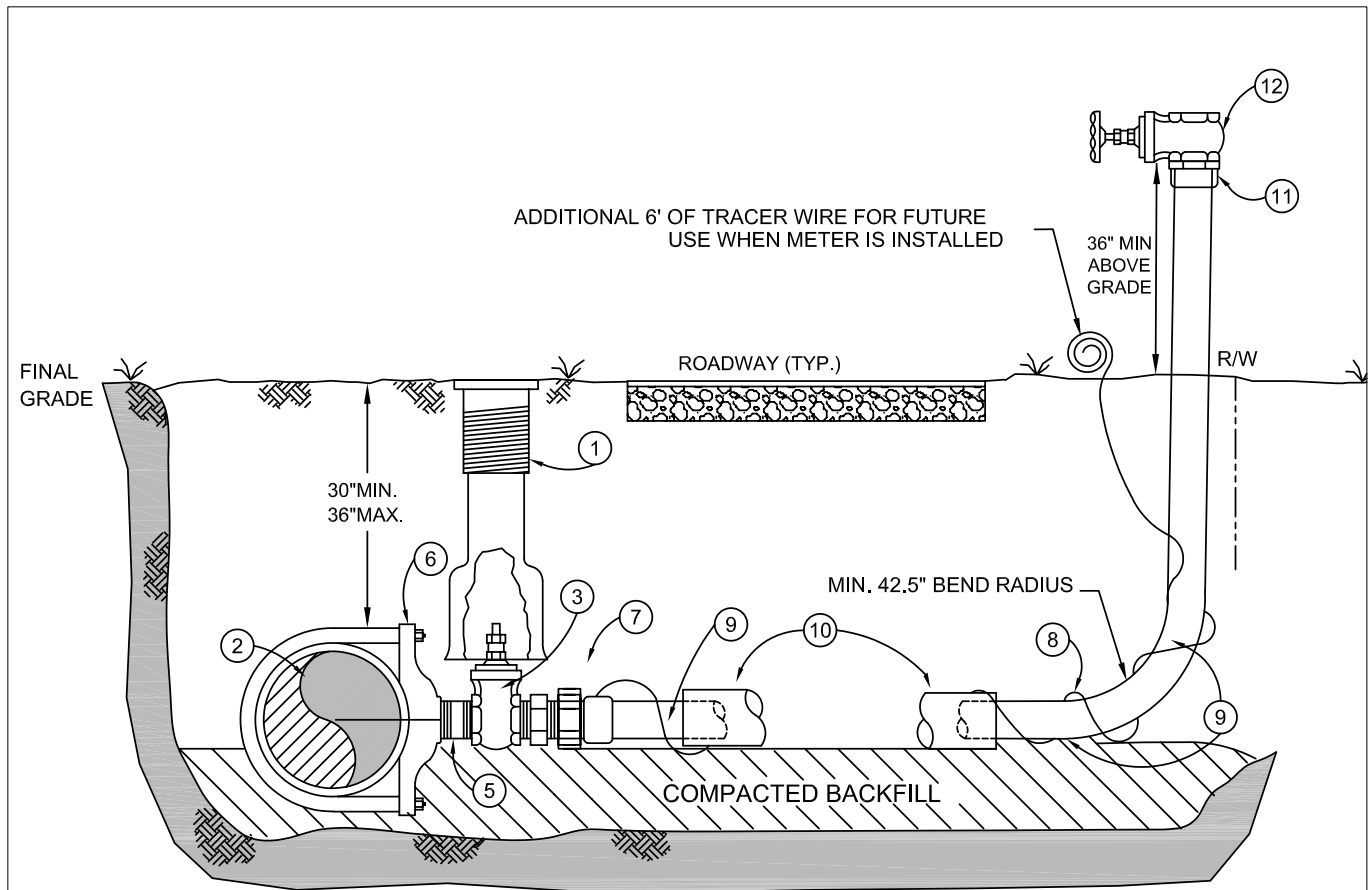

MATERIALS	
ITEM	DESCRIPTION
1	VALVE BOX
2	4", 6", 8", 12" WATER MAIN
3	2" GATE VALVE, SQUARE NUT, RESILIENT WEDGE
5	2" x 6" LONG LOW LEAD BRASS NIPPLE
6	4", 6", 8" OR 12" x 2" SERVICE SADDLE OR TAPPED TEE
7	MIP x CTS PE COMPRESSION COUPLING FORD CATALOG #C84-77-G-NL OR APPROVED EQUAL
8	TRACER WIRE, BLUE, # 10 AWG
9	2" CTS POLYETHYLENE WATER SERVICE, BLUE SDR-9
10	4" BLUE PVC SLEEVE, SCH 40
11	2" SHARKBITE MALE NPT ADAPTER SB115450M
12	2" BRASS GATE VALVE

ITEMS 11 AND 12 TO BE REMOVED BY CONTRACTOR UPON ACCEPTANCE OF WATER SYSTEM BY GRU.
CONTRACTOR TO INSTALL ALLIANCE PLASTICS CO #55 PLUG INTO END OF POLYETHYLENE PIPE.

Revision Date:
12/10/2018



Gainesville Regional Utilities
Potable Water Construction Details

2" CTS POLYETHYLENE SERVICE ROADWAY CROSSING

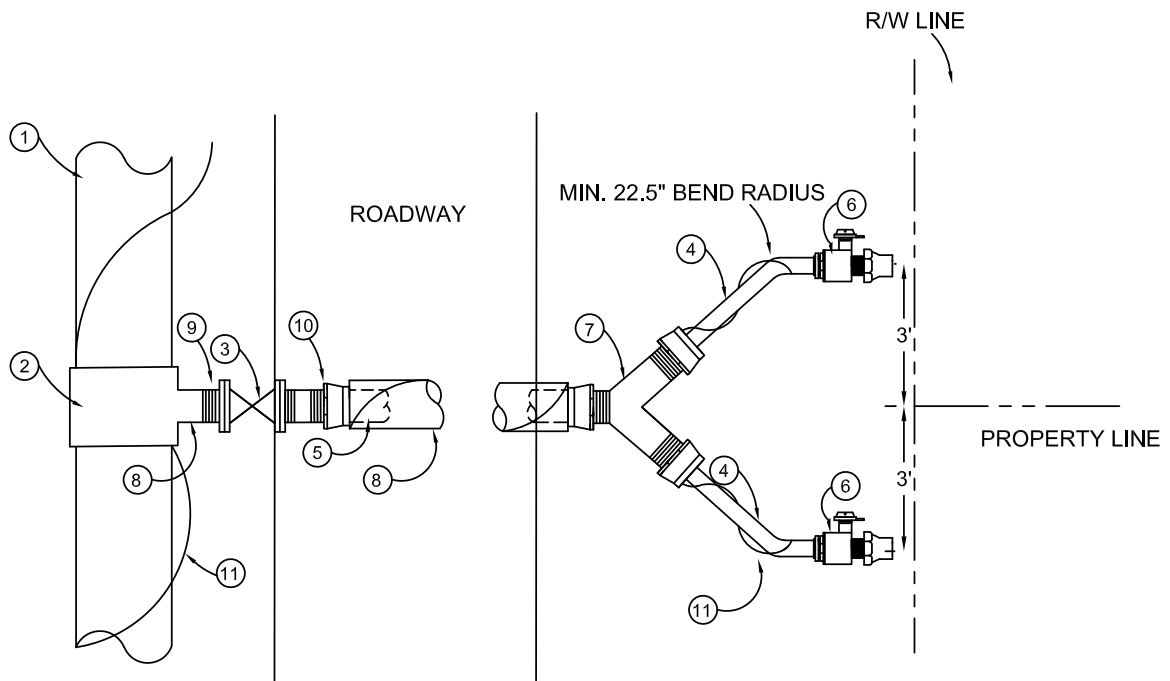

MATERIALS

ITEM	DESCRIPTION	
1	4", 6", 8", 12"	WATER MAIN
2	4", 6", 8", 12"	SERVICE SADDLE W/2" FIP THREADS
3	2"	GATE VALVE & BOX, W/SQUARE OPERATING NUT
4	1"	POLYETHYLENE TUBING, BLUE, SDR-9, CTS
5	2"	POLYETHYLENE TUBING, BLUE, SDR-9, CTS
6	5/8" x3/4"	WATER METER YOKE VALVE (FORD B94-324W-G-NL)
	1"	WATER METER YOKE VALVE (FORD B94-344W-G-NL)
7	2"X1"	BRASS GRIP JOINT WYE OR TEE (FORD Y44-274-G-NL)
8	4"	BLUE SCH 40 PVC OR POLYETHYLENE SLEEVE
9	2" X 2 1/2" LONG	BRASS NIPPLE
10	2" MPT X COMP.	BRASS GRIP-JOINT COUPLING
11		TRACER WIRE, BLUE, # 10 AWG

- NOTES:**
1. ALL FITTINGS FOR POLYETHYLENE TUBING ARE COMPRESSION TYPE (GRIP JOINT).
 2. TRACER WIRE SHALL BE SPIRALED AROUND THE TUBING, TAPED EVERY TEN FEET AND CONNECTED TO THE MAIN LINE TRACER WIRE AND AT WYE USING TRACER-LOCK PART # TL-LUG-55 CONNECTORS.
 3. NO INSERTS (STIFFENERS) SHALL BE PLACED IN ENDS OF TUBING.
 4. SEE W-8.0.1 FOR WATER METER ASSEMBLY INSTALLATION.
- FORD= FORD METER BOX COMPANY

Revision Date:
12/05/2018



Gainesville Regional Utilities
Potable Water Construction Details

DOUBLE 2 INCH POLYETHYLENE WATER SERVICE

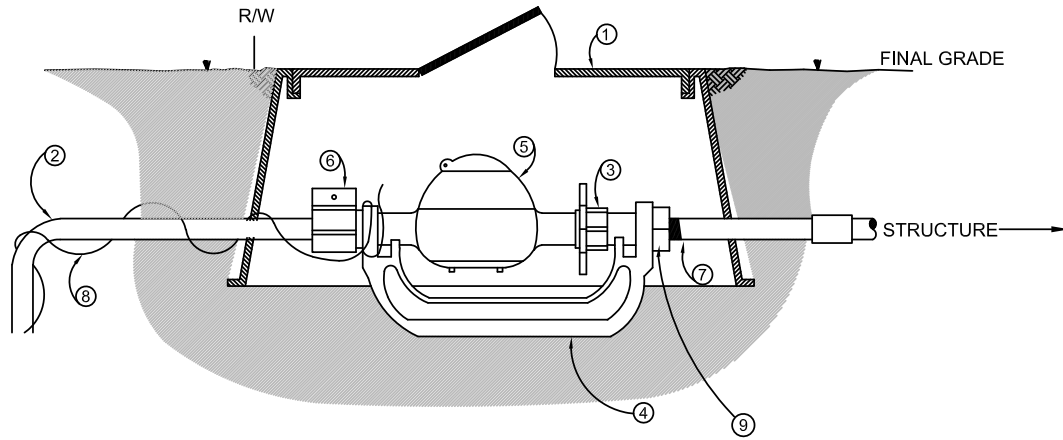

MATERIALS

ITEM	DESCRIPTION	
1	METER BOX - 5/8" X 3/4" OR 1"	(BY CONTRACTOR, CARSON PART NO. 1419-12-6-H-K-WOK-0F0)
2	1" POLYETHYLENE TUBING, BLUE, SDR-9	(BY CONTRACTOR) - MIN. 22.5" BEND RADIUS
3	YOKE EXPANSION	(BY GRU)
4	YOKE BAR - 5/8" X 3/4"	(BY CONTRACTOR, FORD NO. Y-502)
	YOKE BAR - 1"	(BY CONTRACTOR, FORD NO. Y-504)
5	WATER METER - 5/8" x 3/4" OR 1"	(BY GRU)
6	METER YOKE VALVE - 5/8" X 3/4"	(BY CONTRACTOR, FORD B94-324W-G-NL or BA94-324W-G-NL)
	METER YOKE VALVE - 1"	(BY CONTRACTOR, FORD B94-344W-G-NL or BA94-344W-G-NL)
7	6" SCH 80 PVC THREADED NIPPLE	(BY CONTRACTOR)
8	TRACER WIRE, BLUE	(BY CONTRACTOR)
9	METER END CONNECTOR - 5/8" X 3/4"	(BY CONTRACTOR, FORD C91-23-NL)
	METER END CONNECTOR - 1"	(BY CONTRACTOR, FORD C91-44-NL)

NOTES:

1. TRACER WIRE SHALL BE SPIRALED AROUND THE TUBING, TAPED EVERY TEN FEET AND CONNECTED TO THE MAIN LINE TRACER WIRE AND AT WYE USING TRACER-LOCK PART #TL-LUG-SS CONNECTORS.
2. GAINESVILLE REGIONAL UTILITIES WILL INSTALL WATER METERS UNLESS OTHERWISE SPECIFIED ON THE APPROVED DRAWINGS.
3. CONTRACTOR SHALL BE RESPONSIBLE FOR INSTALLATION OF THE METER BOX AND METER YOKE ASSEMBLY (5/8" - 1" METERS).
4. NO INSERTS (STIFFENERS) SHALL BE PLACED INTO ENDS OF TUBING.

FORD = FORD METER BOX COMPANY

Revision Date:
12/18/2018



Gainesville Regional Utilities
Potable Water Construction Details

POLYETHYLENE WATER METER ASSEMBLY BY CONTRACTOR: 5/8" X 3/4", 3/4", & 1"

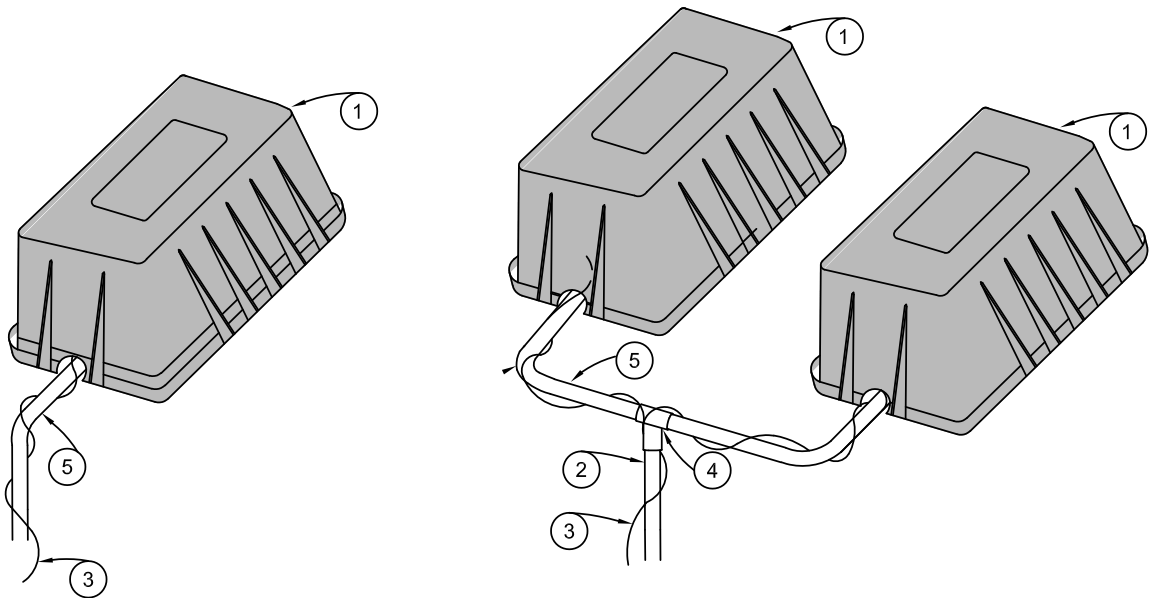

SINGLE SERVICE

DUAL SERVICE

M A T E R I A L S	
ITEM	DESCRIPTION
1	METER BOX
2	2" POLYETHYLENE TUBING, BLUE, SDR-9, CTS
3	TRACER WIRE, COPPER, BLUE INSULATED, #10 AWG
4	1" X 1" X 2" BRASS GRIP JOINT TEE OR WYE (FORD Y44-274-G-NL)
5	1" POLYETHYLENE TUBING, BLUE, SDR-9, CTS-MIN. 22.5" BEND RADIUS

NOTES:

1. GAINESVILLE REGIONAL UTILITIES WILL INSTALL WATER METERS.

Revision Date: 12/05/2018		Gainesville Regional Utilities Potable Water Construction Details SINGLE & DUAL WATER METER ASSEMBLY CONSTRUCTION
------------------------------	---	---

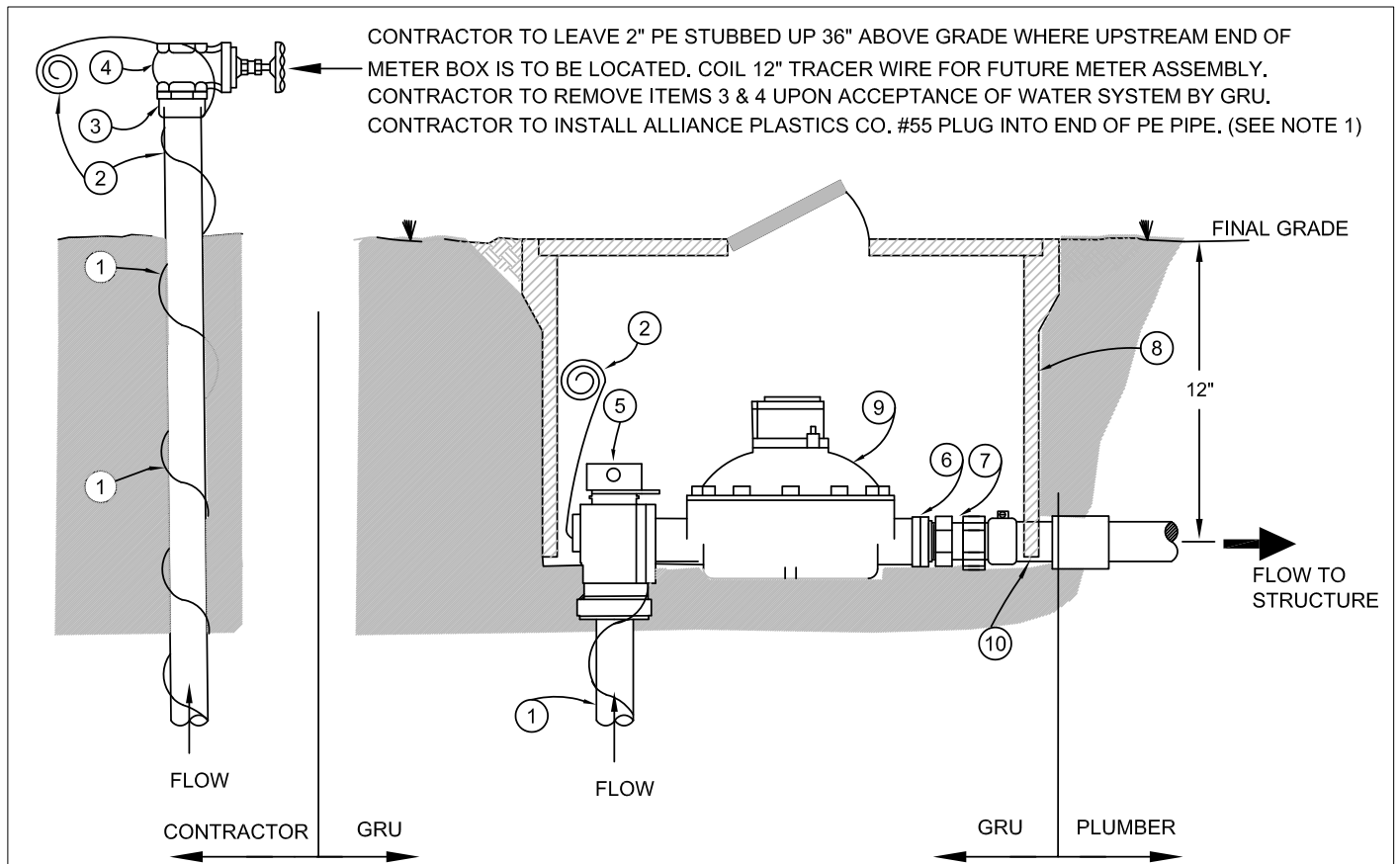

M A T E R I A L S

ITEM	DESCRIPTION
1	2" CTS BLUE SDR-9 POLYETHYLENE (PE) TUBING (BY CONTRACTOR)
2	TRACER WIRE, BLUE (BY CONTRACTOR)
3	SHARKBITE MALE NPT ADAPTER SB115450m (BY CONTRACTOR)
4	2" BRASS GATE VALVE (BY CONTRACTOR)
5	BRASS ANGLE METER STOP-A.Y. MCDONALD 74602BCSQ (BY GRU)
6	BRASS FLANGE ADAPTER (BY GRU)
7	2" BRASS PACK JOINT COUPLING-FORD C87-77-NL (BY GRU)
8	METER BOX, (OLDCASTLE MB66) IN TRAFFIC AREAS, CARSON 12H SERIES IN GREEN AREAS (BY GRU)
9	1-1/2", 2" WATER METER (BY GRU)
10	2" PVC PIPE (BY GRU)

NOTE:

1. GAINESVILLE REGIONAL UTILITIES WILL INSTALL WATER METER ASSEMBLY
 2. TRACER WIRE SHALL BE SPIRALED AROUND THE TUBING, TAPED EVERY TEN FEET AND CONNECTED TO THE MAIN LINE TRACER WIRE USING TRACER-LOCK PART#TL-LUG-SS CONNECTORS.
 3. NO INSERTS (STIFFENERS) SHALL BE PLACED INTO ENDS OF TUBING.
- FORD = FORD METER BOX COMPANY

Revision Date:	 More than Energy	Gainesville Regional Utilities Potable Water Construction Details
03/22/19		WATER METER ASSEMBLY: 1 1/2" & 2"

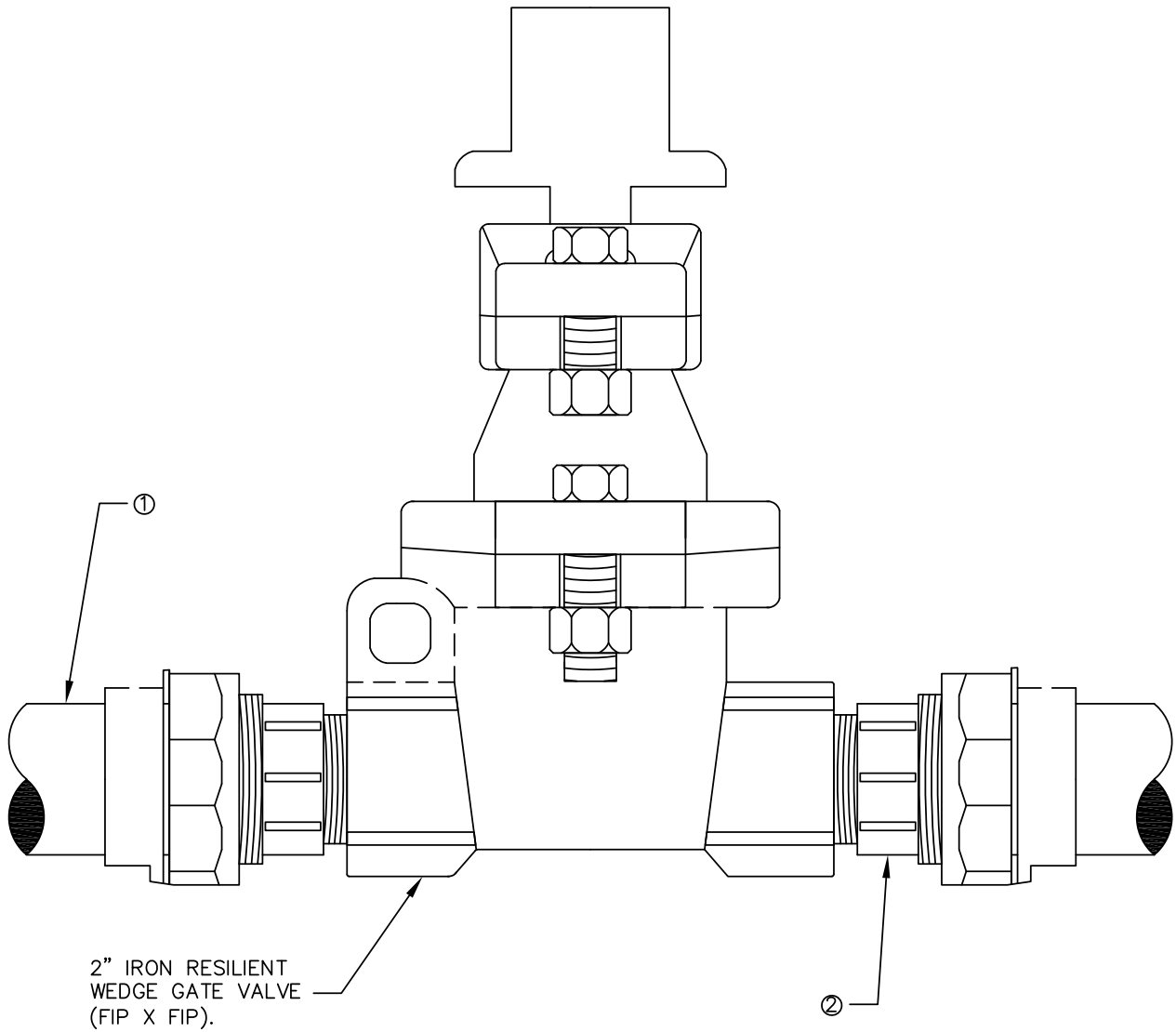

①	②	FORD PART #
2" POLYETHYLENE (PE) PIPE	2" BRASS GRIP JOINT COUPLING	C84-77-G-NL
2" PVC PIPE	2" BRASS PACK JOINT COUPLING	C87-77-NL

FORD=FORD METER BOX COMPANY

Revision Date:
9/28/2018



Gainesville Regional Utilities
Potable Water Construction Details
2" GATE VALVE INSTALLATION FOR PVC OR PE PIPE

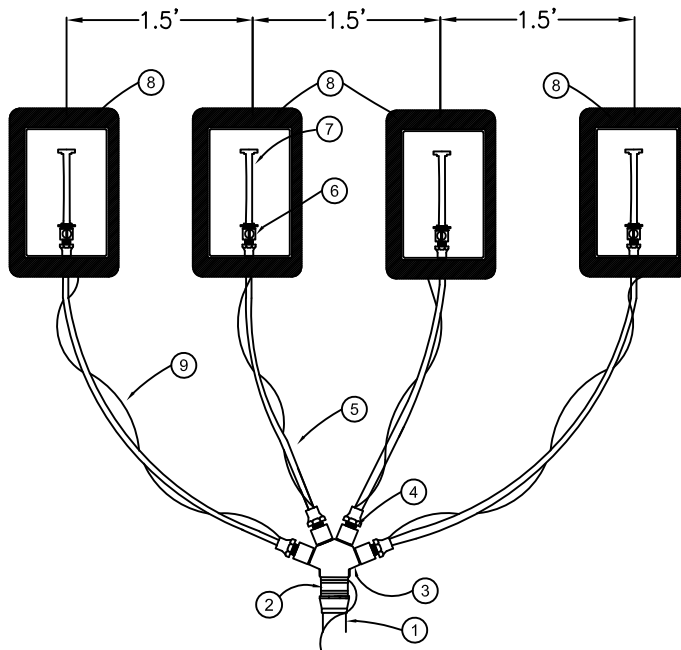

MATERIALS		
ITEM	DESCRIPTION	
1	2"	POLYETHYLENE TUBING, BLUE, SDR-9, CTS
2	2" MPT X COMP.	BRASS GRIP JOINT COUPLING (FORD C84-77-G-NL)
3	2" X 1" FIP	BRASS FOUR-SERVICE WYE (FORD Y-11-474-NL)
4	1" MPT X COMP.	BRASS GRIP JOINT COUPLING (FORD C84-44-G-NL)
5	1"	POLYETHYLENE TUBING, BLUE, SDR-9, CTS - MIN. 22.5" BEND RADIUS
6	5/8" X 3/4"	WATER METER YOKE VALVE (FORD B94-324W-G-NL or BA94-324W-G-NL)
	1"	WATER METER YOKE VALVE (FORD B94-344W-G-NL or BA94-344W-G-NL)
7	5/8" X 3/4"	YOKE BAR (FORD Y-502)
	1"	YOKE BAR (FORD Y-504)
8	5/8" X 3/4" OR 1"	METER BOX(CARSON 21419-12-6-H-R-WOK-0F0)
9		TRACER WIRE, BLUE

- NOTES:**
1. ALL FITTINGS FOR POLYETHYLENE TUBING ARE COMPRESSION TYPE (GRIP JOINT).
 2. TRACER WIRE SHALL BE SPIRALED AROUND THE TUBING, TAPED EVERY TEN FEET AND CONNECTED TO THE MAIN LINE TRACER WIRE AND AT WYE USING TRACER-LOCK PART #TL-LUG-SS CONNECTORS.
 3. CONTRACTOR SHALL BE RESPONSIBLE FOR INSTALLATION OF THE METER BOX AND METER YOKE ASSEMBLY (5/8"-1" METERS). SEE WATER METER ASSEMBLY DETAIL W-8.0.1.
 4. GAINESVILLE REGIONAL UTILITIES WILL INSTALL WATER METERS UNLESS OTHERWISE SPECIFIED ON THE APPROVED DRAWINGS.
 5. NO INSERTS (STIFFENER) SHALL BE PLACED INTO ENDS OF TUBING.
FORD= FORD METER BOX COMPANY

Revision Date:		Gainesville Regional Utilities Potable Water Construction Details MULTIPLE GANG METER ASSEMBLY
4/12/2019		

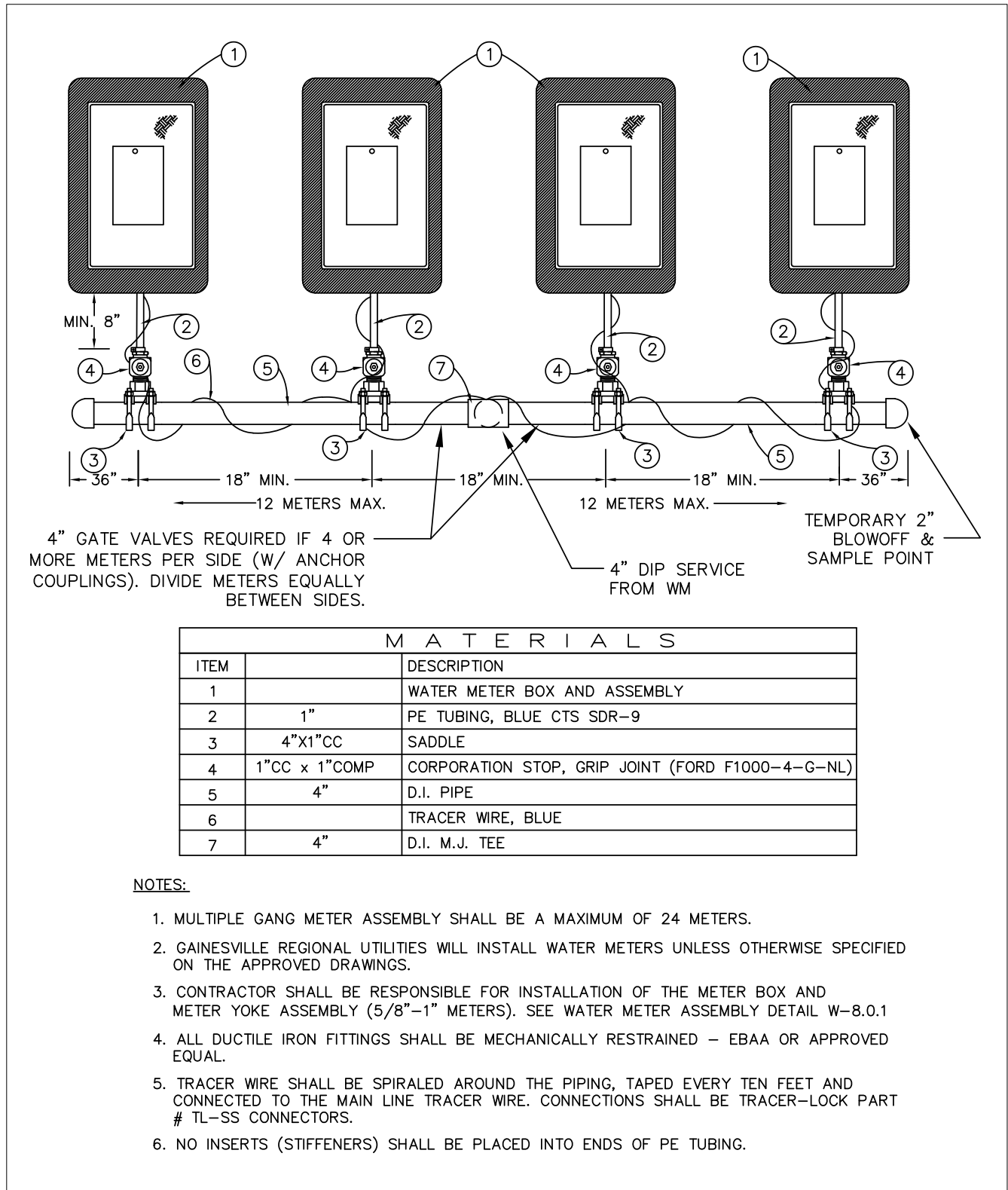

M A T E R I A L S		
ITEM		DESCRIPTION
1		WATER METER BOX AND ASSEMBLY
2	1"	PE TUBING, BLUE CTS SDR-9
3	4"X1"CC	SADDLE
4	1"CC x 1"COMP	CORPORATION STOP, GRIP JOINT (FORD F1000-4-G-NL)
5	4"	D.I. PIPE
6		TRACER WIRE, BLUE
7	4"	D.I. M.J. TEE

NOTES:

1. MULTIPLE GANG METER ASSEMBLY SHALL BE A MAXIMUM OF 24 METERS.
2. GAINESVILLE REGIONAL UTILITIES WILL INSTALL WATER METERS UNLESS OTHERWISE SPECIFIED ON THE APPROVED DRAWINGS.
3. CONTRACTOR SHALL BE RESPONSIBLE FOR INSTALLATION OF THE METER BOX AND METER YOKE ASSEMBLY (5/8"-1" METERS). SEE WATER METER ASSEMBLY DETAIL W-8.0.1
4. ALL DUCTILE IRON FITTINGS SHALL BE MECHANICALLY RESTRAINED - EBAA OR APPROVED EQUAL.
5. TRACER WIRE SHALL BE SPIRALED AROUND THE PIPING, TAPED EVERY TEN FEET AND CONNECTED TO THE MAIN LINE TRACER WIRE. CONNECTIONS SHALL BE TRACER-LOCK PART # TL-SS CONNECTORS.
6. NO INSERTS (STIFFENERS) SHALL BE PLACED INTO ENDS OF PE TUBING.

Revision Date:

02/05/2019



Gainesville Regional Utilities
Potable Water Construction Details

MULTIPLE GANG METER ASSEMBLY - DIP HEADER

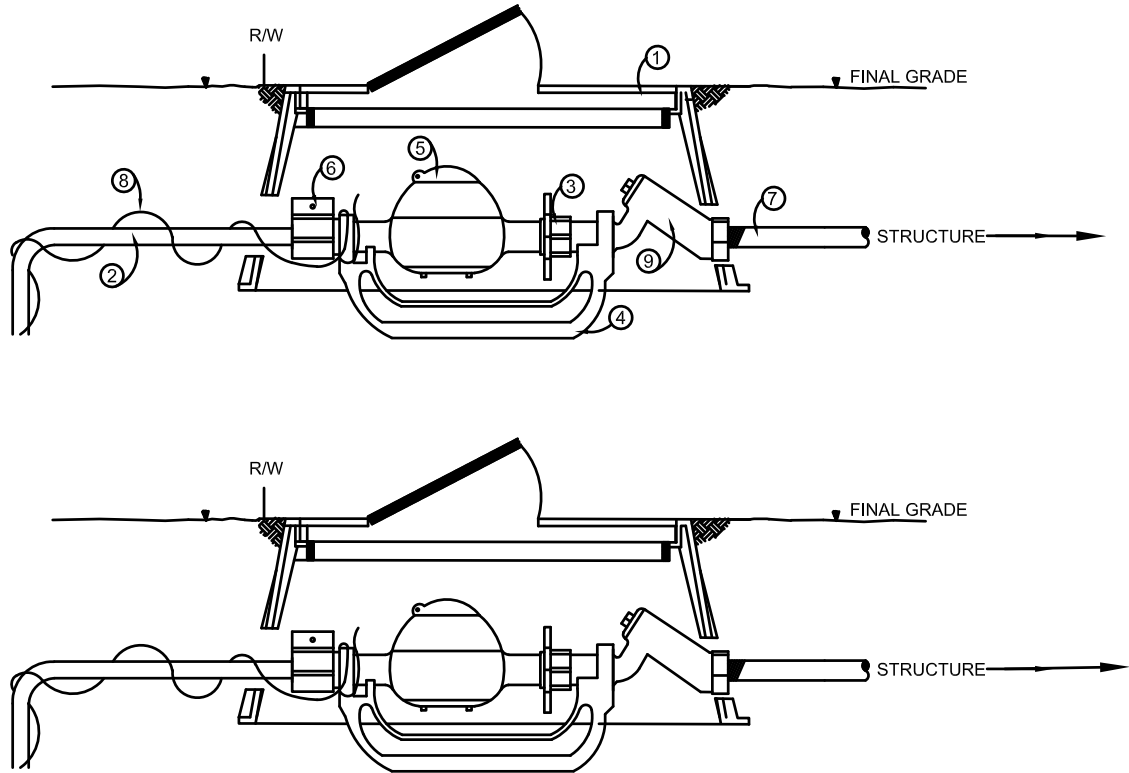

M A T E R I A L S

ITEM	DESCRIPTION
1	METER BOX (BY GRU)
2	1" CTS BLUE PE WATER SERVICE TUBING SDR-9 (BY CONTRACTOR)-MIN. 22.5" BEND RADIUS
3	YOKE EXPANSION (BY GRU)
4	YOKE BAR (BY GRU)
5	WATER METER - 5/8" x 3/4" (BY GRU)
6	METER YOKE VALVE (BY CONTRACTOR - FORD B94-324W-G-NL)
7	SCH 80 PVC PIPE - 3/4" NPT THREADS X 12" LENGTH (GRU)
8	TRACER WIRE, COPPER, BLUE INSULATED, #10 AWG (BY CONTRACTOR)
9	3/4" STRAIGHT CARTRIDGE DUAL CHECK VALVE (FORD - HHCH91-323-NL), METER YOKE NOSE INLET BY FEMALE IRON PIPE OUTLET. (BY GRU)

NOTE:

1. CONTRACTOR TO BE RESPONSIBLE FOR 1 YR. WARRANTY PERIOD FOR INSTALLATION OF WATER SERVICE, EXCLUDING ITEMS PROVIDED BY GRU.
2. APPLIES ONLY TO RESIDENTIAL POTABLE WATER SERVICE WHERE RECLAIMED WATER SERVICE IS OR WILL BE INSTALLED.
3. MATERIALS PROVIDER (GRU OR CONTRACTOR) CAN BE RE-EVALUATED FOR COSTS/CODES AND WILL REQUIRE MANAGEMENT REVIEW AND APPROVAL.

Revision Date:
10/22/18



Gainesville Regional Utilities
Potable Water Construction Details

**POTABLE METER BACKFLOW PREVENTER IN
RECLAIMED SERVICE AREA**

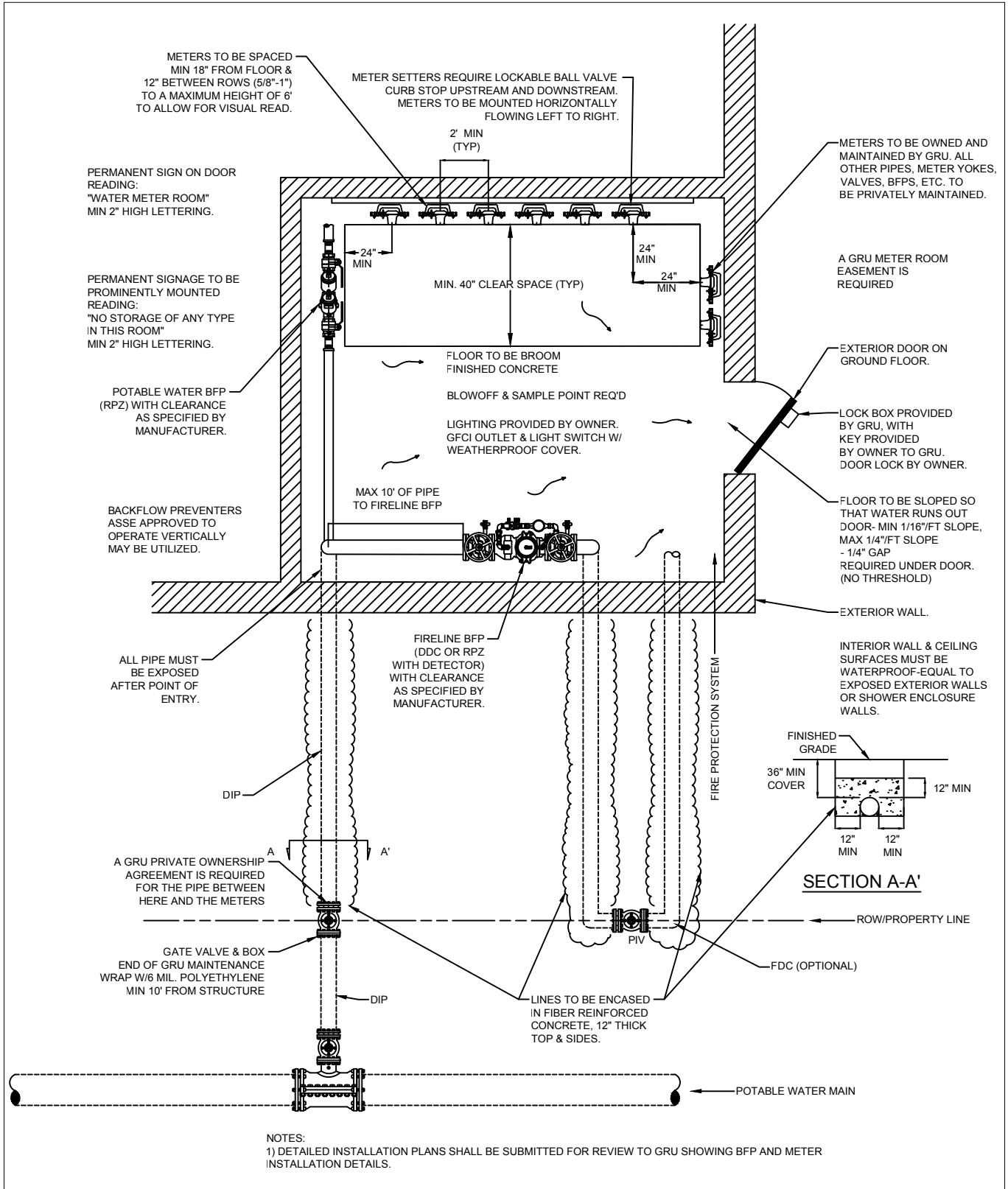

<p>Revision Date: 08/22/2016</p>		<p align="center"> Gainesville Regional Utilities Potable Water Construction Details INSIDE WATER METERS - ROOM </p>
--------------------------------------	---	--

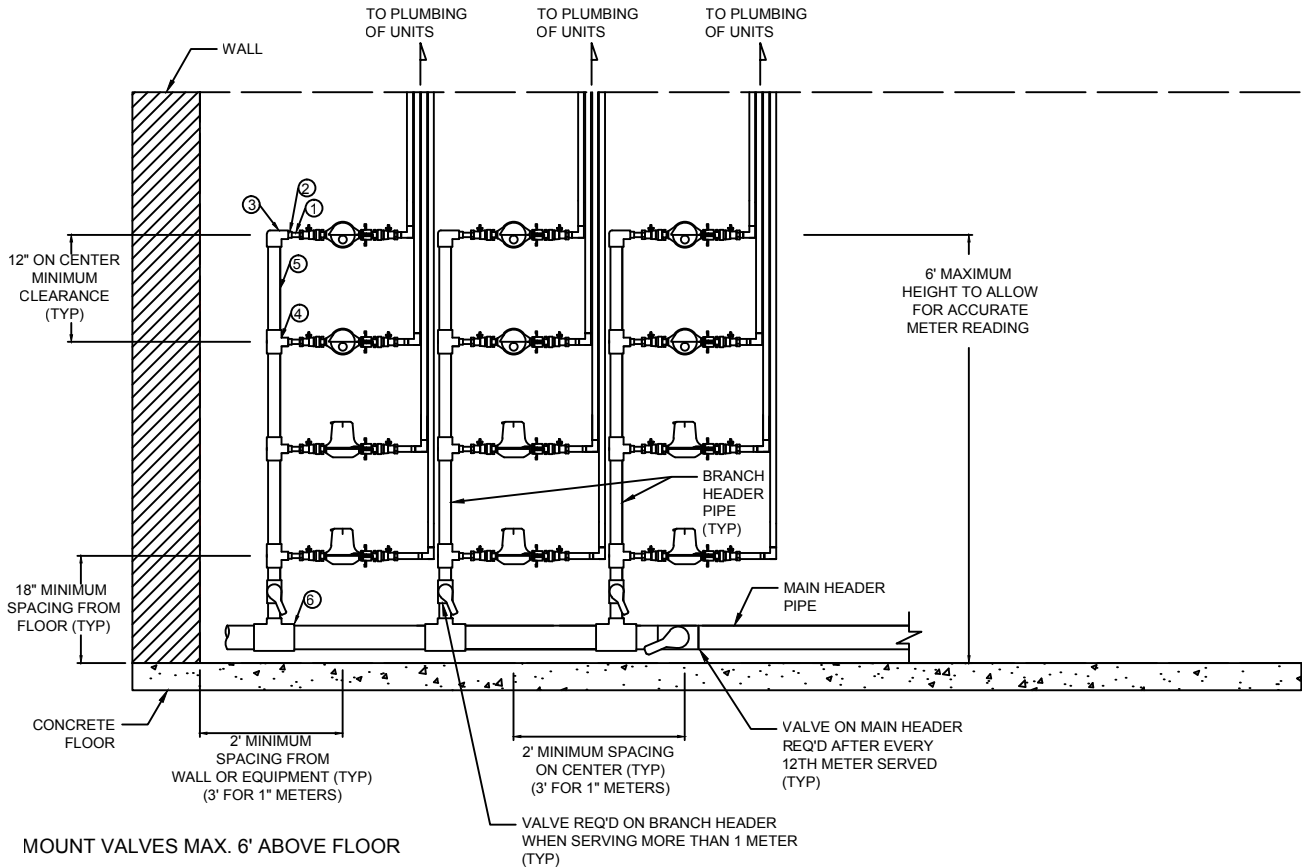

MOUNT VALVES MAX. 6' ABOVE FLOOR

MATERIALS		
ITEM		DESCRIPTION
1	3/4" (1")*	PVC PIPE
2	1-1/2" X 3/4" (1")*	PVC REDUCING BUSHING
3	1-1/2"	PVC ELBOW
4	1-1/2" X 3/4" (1")*	PVC TEE
5	1-1/2"	PVC PIPE
6	4" X 1-1/2"	PVC TEE

*(FOR 1" METERS)

- NOTES: -MAXIMUM FOUR 5/8" METERS PER 1-1/2" BRANCH HEADER.
 -MAXIMUM FIVE 3/4" METERS PER 2" BRANCH HEADER.
 -ONLY SENSUS iPERL METERS WILL BE USED AND MUST BE MOUNTED HORIZONTALLY FLOWING LEFT TO RIGHT FOR READABILITY.
 -MINIMUM CLEAR SPACE OF 40" IN FRONT AND 24"(5/8"-3/4" ONLY, 36" FOR 1" & LARGER METERS) TO EACH SIDE OF METERS AND METERING EQUIPMENT SHALL BE MAINTAINED AT ALL TIMES FOR READING AND TESTING.
 -PERMANENTLY LABEL EACH METER YOKE WITH UNIT NUMBER.
 -METERS 5/8" TO 1" WILL BE SENSUS iPERL AND MUST BE MOUNTED HORIZONTALLY FLOWING LEFT TO RIGHT FOR READABILITY.

Revision Date: 08/22/2016		Gainesville Regional Utilities Potable Water Construction Details 5/8" - 1" INSIDE WATER METERS-ROOM
------------------------------	---	---

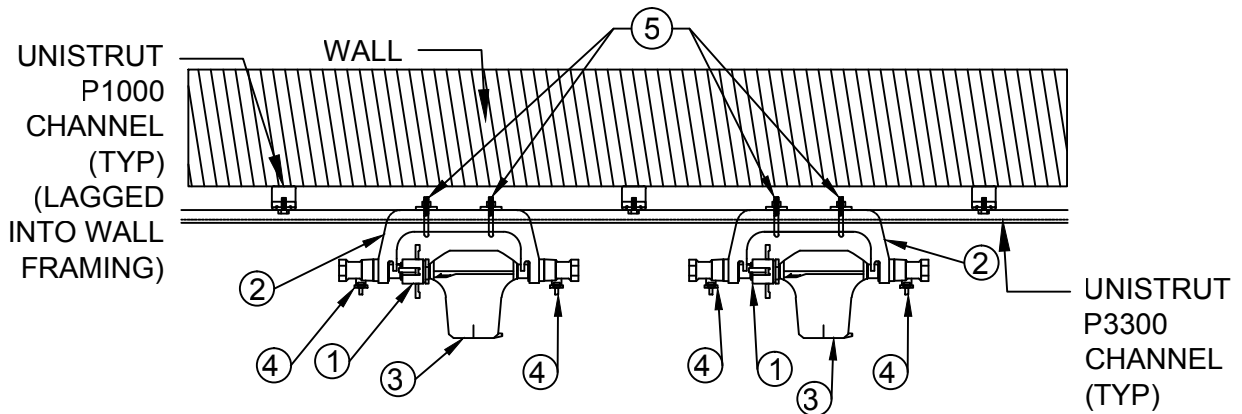

MATERIALS	
ITEM	DESCRIPTION
1	YOKE EXPANSION
2	YOKE BAR - 5/8" X 3/4" FORD METER BOX CO. #Y502
3	SENSUS iPERL 5/8" METER
4	METER BALL VALVE - 5/8" X 3/4" FORD METER BOX CO. #B-91-223-W
5	U-BOLT WITH WASHERS AND NUTS-SUPERSTRUT U-501/2 OR EQUAL

PLAN VIEW

NOT TO SCALE

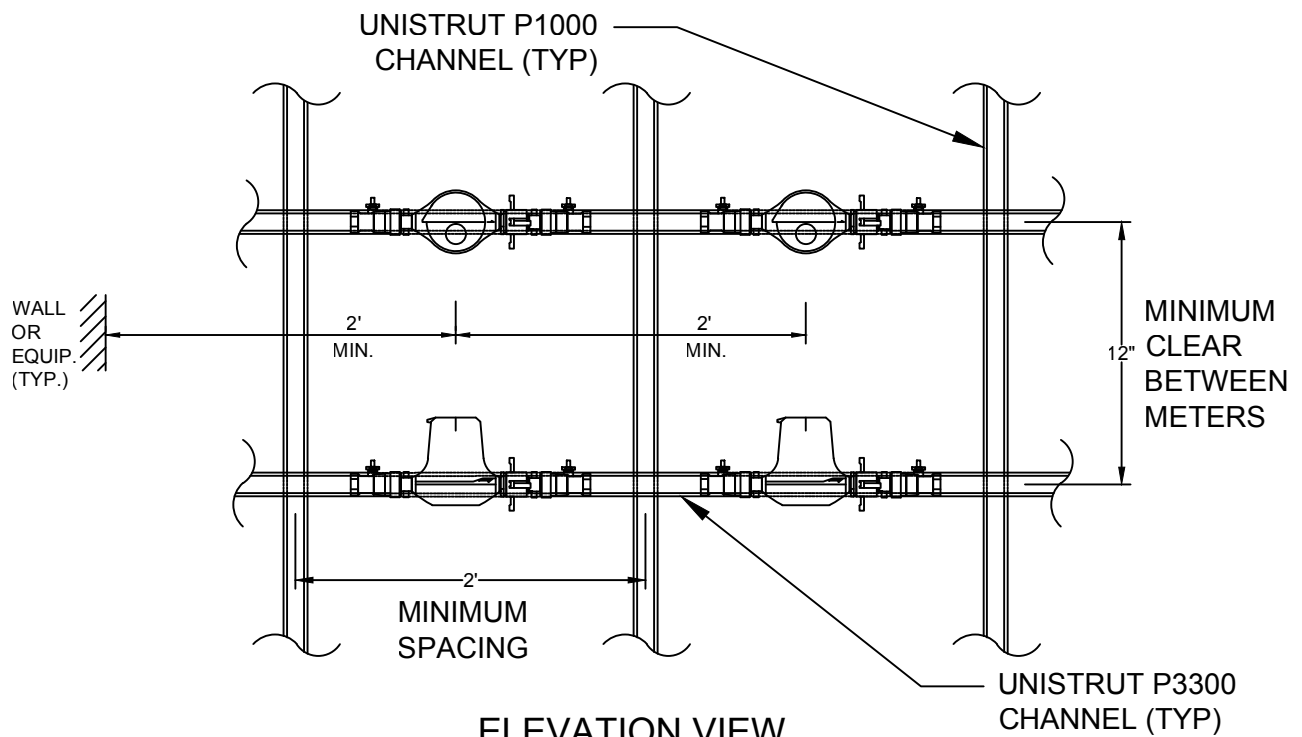

ELEVATION VIEW

NOT TO SCALE

Revision Date:
08/22/2016



Gainesville Regional Utilities
Potable Water Construction Details

5/8" INSIDE WATER METERS-ROOM

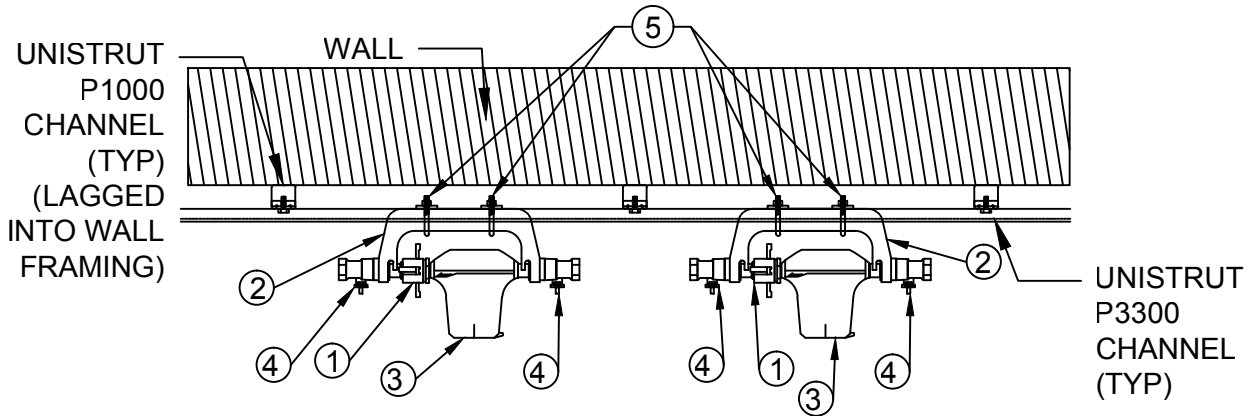

MATERIALS	
ITEM	DESCRIPTION
1	YOKE EXPANSION
2	YOKE BAR - 1" FORD METER BOX CO. #Y504
3	SENSUS iPERL 1" METER
4	METER BALL VALVE - 1" FORD METER BOX CO. #B-91-334-W
5	U-BOLT WITH WASHERS AND NUTS-SUPERSTRUT U-501/2 OR EQUAL

PLAN VIEW

NOT TO SCALE

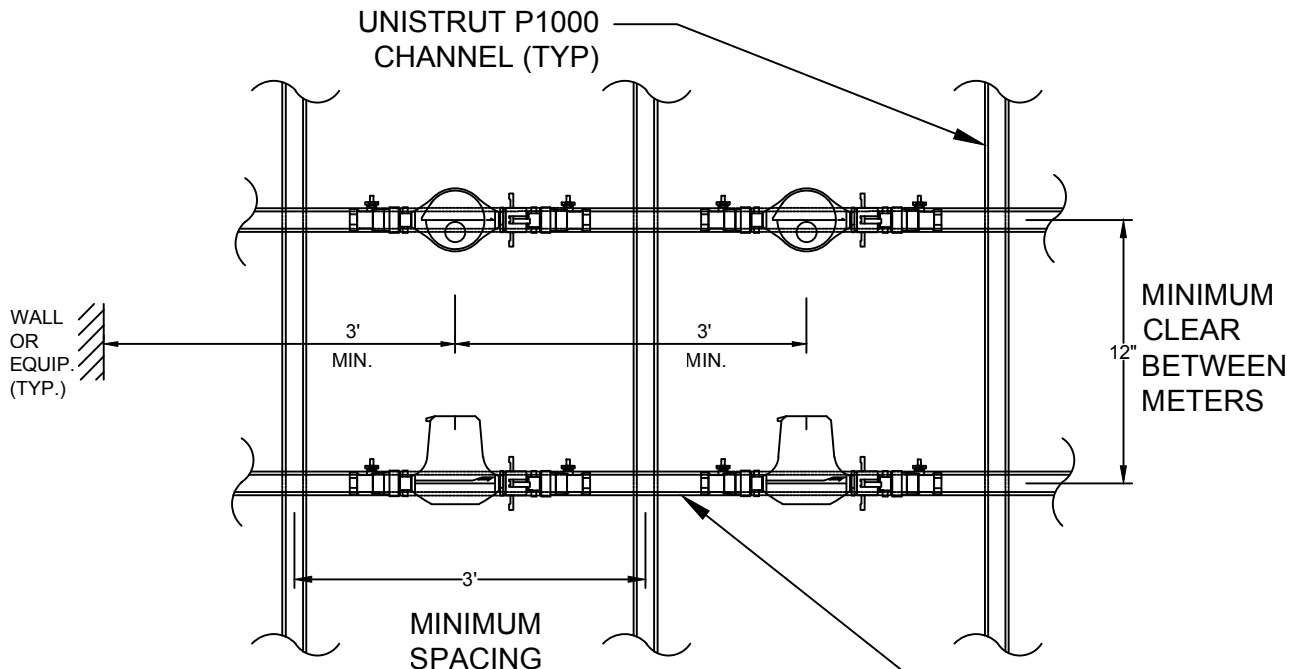

ELEVATION VIEW

NOT TO SCALE

Revision Date: 08/22/2016		Gainesville Regional Utilities Potable Water Construction Details 1" INSIDE WATER METERS-ROOM
------------------------------	--	---

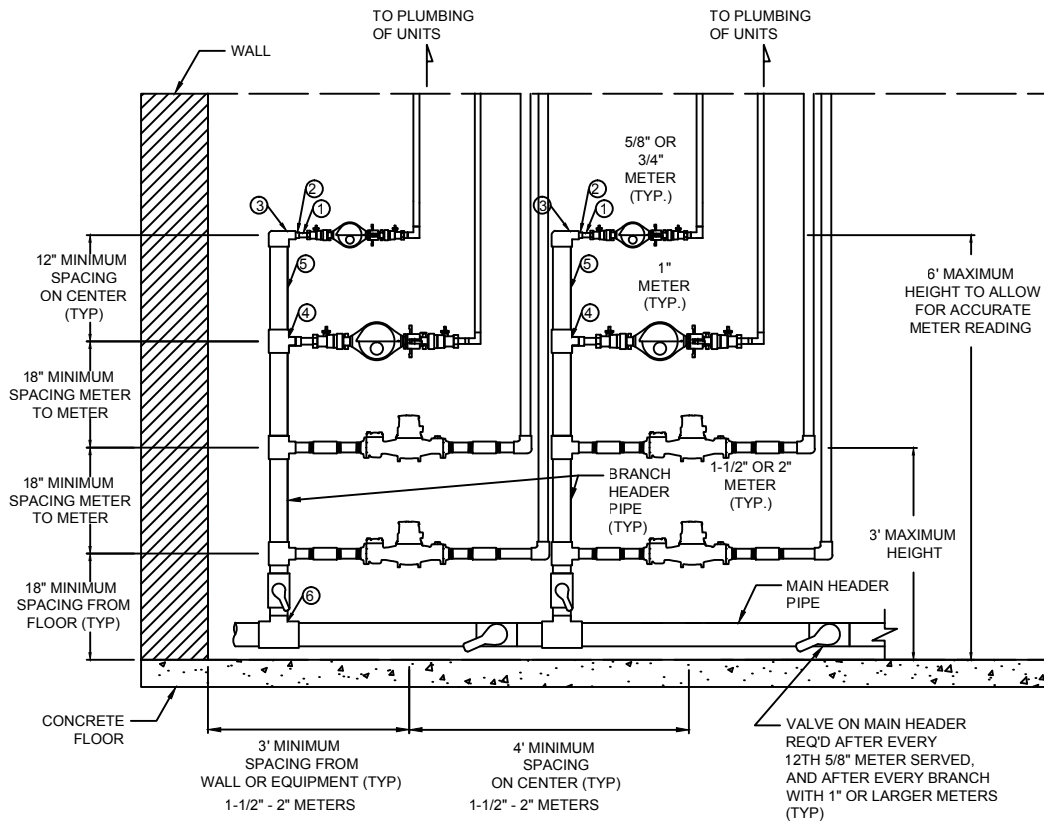

SEE W-8.9 FOR 1-1/2" & 2" METER MATERIALS

MATERIALS		
ITEM	DESCRIPTION	
1	3/4" (1")*	PVC PIPE
2	3" X 3/4" (1")*	PVC REDUCING BUSHING
3	3"	PVC ELBOW
4	3" X 3/4" (1")*	PVC TEE
5	3"	PVC PIPE
6	4" X 3"	PVC TEE

*(FOR 1" METERS)

- NOTES: -MAXIMUM FOUR 5/8" METERS PER 1-1/2" BRANCH HEADER.
 -MAXIMUM FIVE 3/4" METERS PER 2" BRANCH HEADER.
 -MINIMUM CLEAR SPACE OF 40" IN FRONT AND 24"(5/8"-3/4" ONLY, 36" FOR 1" & LARGER METERS) TO EACH SIDE OF METERS AND METERING EQUIPMENT SHALL BE MAINTAINED AT ALL TIMES FOR READING AND TESTING.
 -PERMANENTLY LABEL EACH METER YOKE WITH UNIT NUMBER.
 -PERMANENTLY LABEL EACH LARGE METER WITH FLOOR OR AREA SUPPLIED.
 -1-1/2" & 2" METERS SHALL BE SENSUS OMNI C2 METERS MOUNTED HORIZONTALLY OR VERTICALLY, FLOWING EITHER DIRECTION.

Revision Date:
08/22/2016



Gainesville Regional Utilities
Potable Water Construction Details

5/8" - 2" INSIDE WATER METERS-ROOM

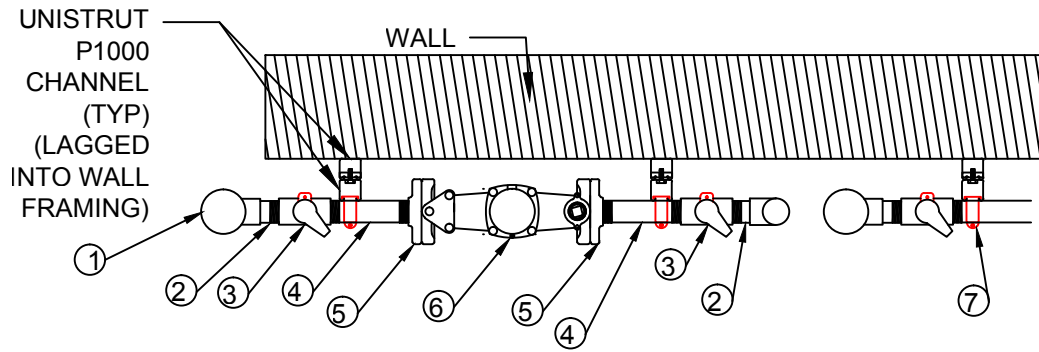

PLAN VIEW

NOT TO SCALE

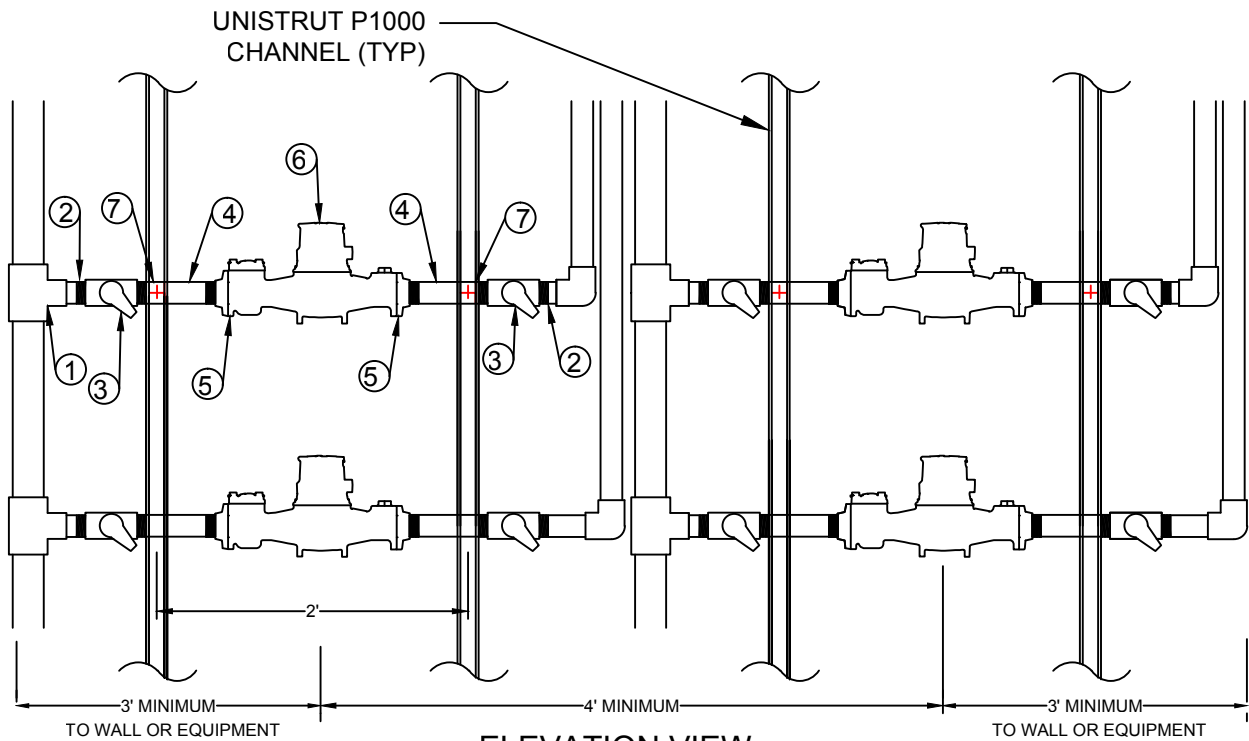

ELEVATION VIEW

NOT TO SCALE

MATERIALS

ITEM	DESCRIPTION
1	3" X 1-1/2" (2")* PVC TEE
2	1-1/2" (2")* SCH 80 PVC NIPPLE (THD x SLIP)
3	1-1/2" (2")* BRASS QUARTER TURN BALL VALVE, PADLOCKABLE
4	1-1/2" (2")* BRASS NIPPLE (THD x THD)
5	1-1/2" (2")* BRASS TAPPED FLANGE
6	1-1/2" (2")* SENSUS OMNI C2 METER
7	1-1/2" (2")* UNISTRUT PIPE CLAMP

*(FOR 2" METERS)

Revision Date:
08/22/2016



Gainesville Regional Utilities
Potable Water Construction Details

1 1/2"-2" INSIDE WATER METERS-ROOM

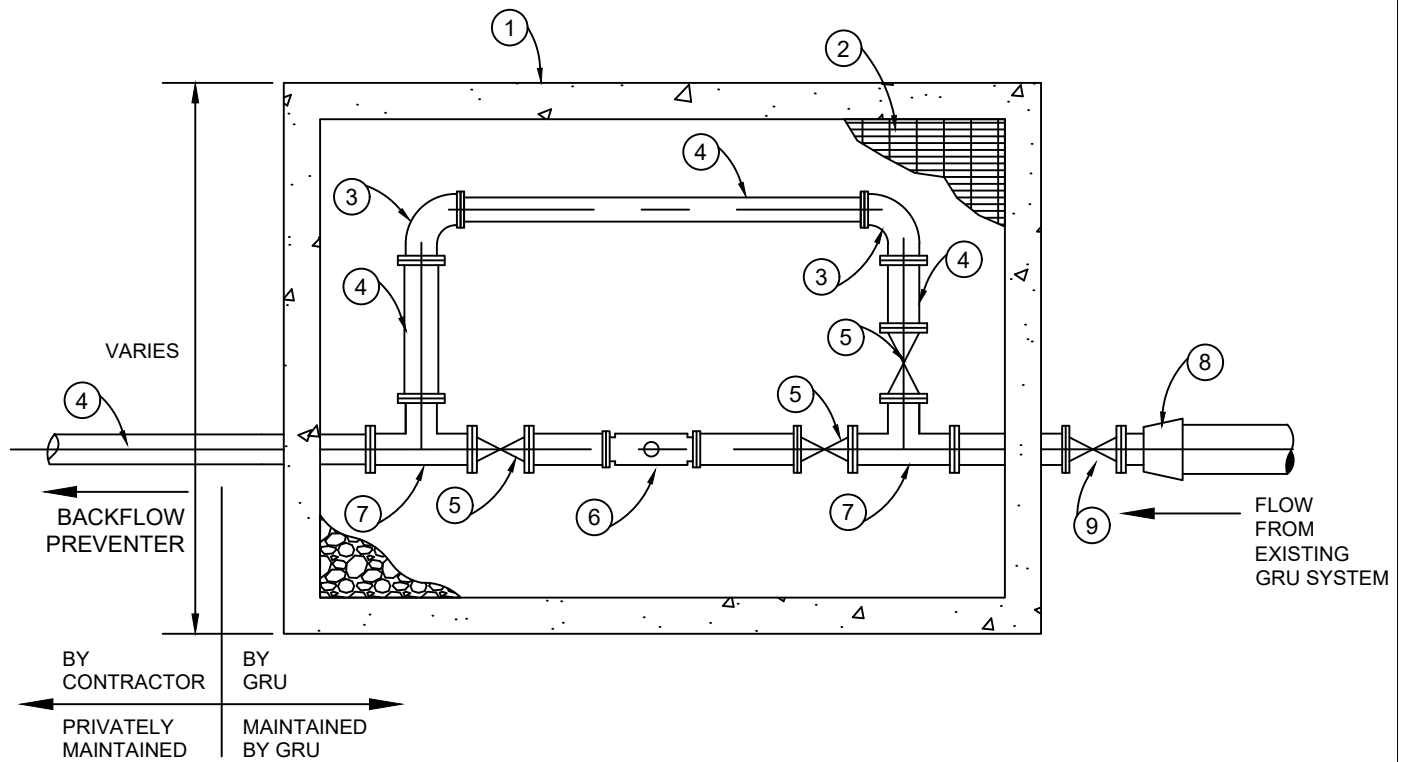

MATERIALS

ITEM	DESCRIPTION
1	PRECAST CONCRETE VAULT
2	ALUMINUM GRATE VAULT COVER
3	D.I. 90° BEND, FL X FL, WITH EBAA MEGAFLANGE
4	DIP W.M.
5	GATE VALVE, FL X FL, WITH EBAA MEGAFLANGE
6	FIRELINE/COMPOUND METER
7	D.I. TEE, FL X FL, WITH EBAA MEGAFLANGE
8	D.I. REDUCER, MJ X MJ WITH EBAA MEGALUGS
9	GATE VALVE, MJ X MJ, WITH EBAA MEGALUG

NOTES:

- METER VAULT SIZE WILL BE DETERMINED IN ACCORDANCE WITH METER SIZE AND TYPE.
- ALL FITTINGS WITHIN VAULT MUST BE FLANGED FITTINGS. ALL FITTINGS SHALL BE STRUCTURALLY SUPPORTED.

<p>Revision Date: 12/11/2018</p>		<p>Gainesville Regional Utilities Potable Water Construction Details</p>
<p>3" OR LARGER METER ASSEMBLY</p>		

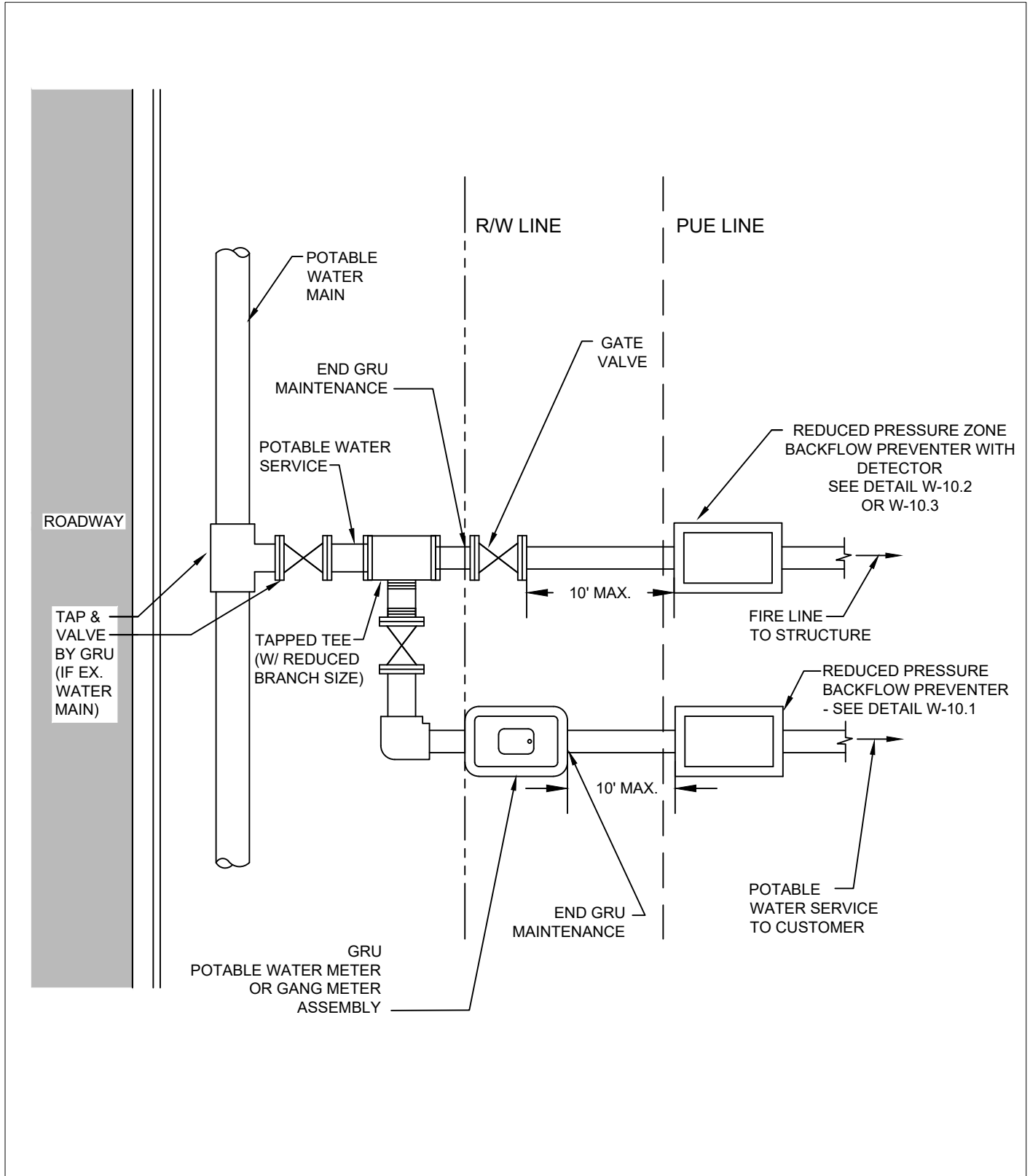

<p>Revision Date: 12/11/2018</p>		<p align="center">Gainesville Regional Utilities Potable Water Construction Details</p> <hr/> <p align="center">POTABLE WATER SERVICE WITH FIRE LINE</p>
--------------------------------------	---	--

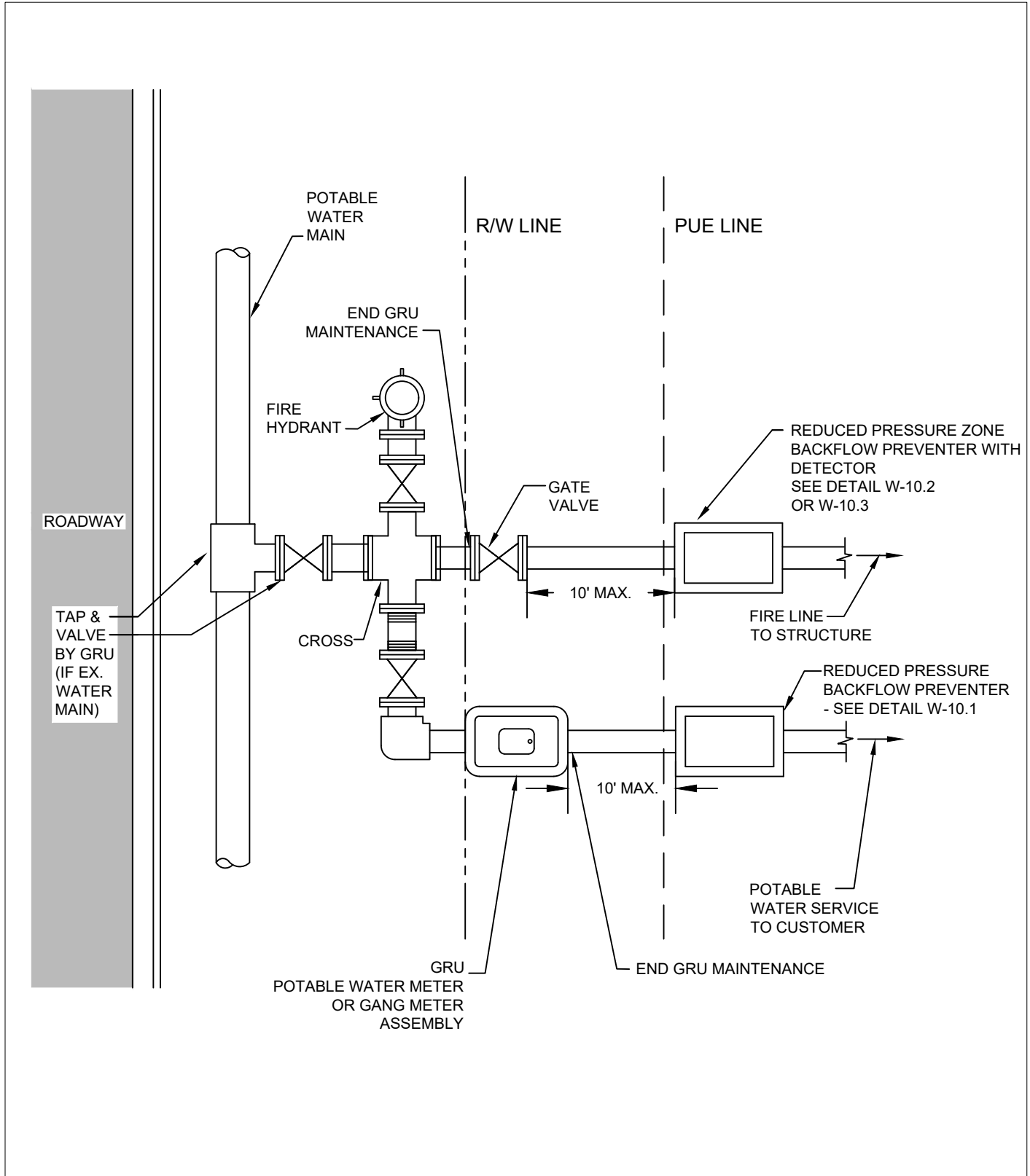

<p>Revision Date: 12/11/2018</p>		<p align="center">Gainesville Regional Utilities Potable Water Construction Details</p> <hr/> <p align="center">POTABLE WATER SERVICE WITH FIRE LINE & HYDRANT</p>
--------------------------------------	---	--

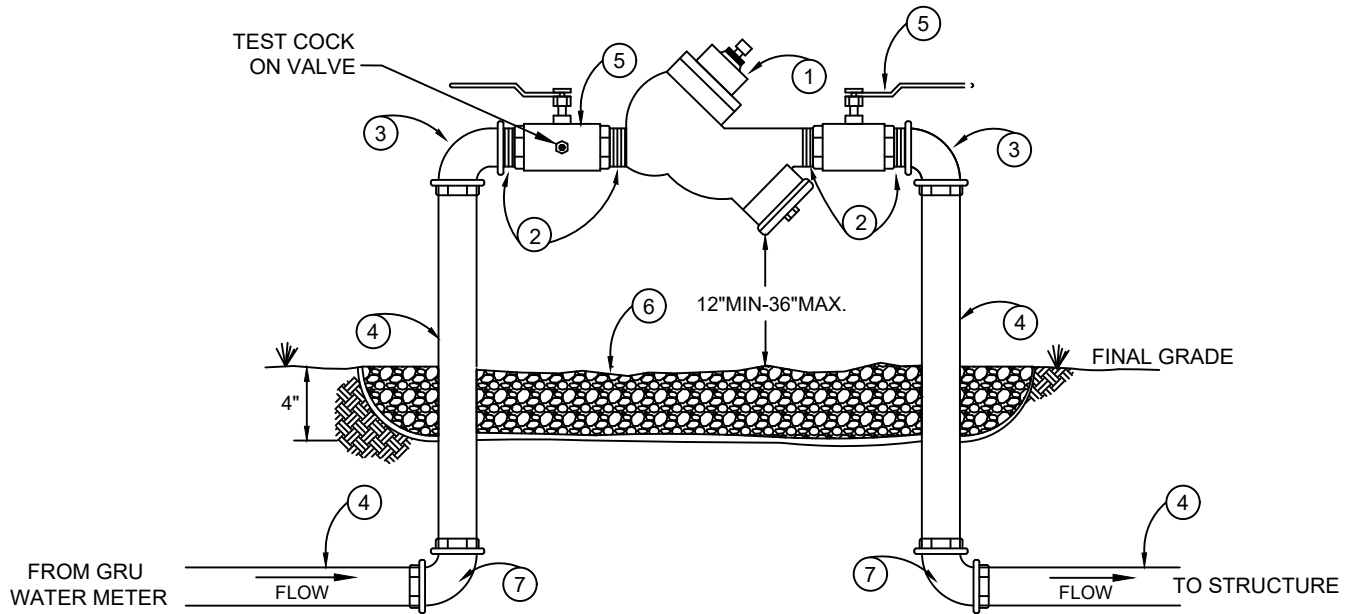

M A T E R I A L S

ITEM	DESCRIPTION
1	3/4", 1", 1-1/2", 2" REDUCED PRESSURE ZONE BACKFLOW PREVENTER
2	3/4", 1", 1-1/2", 2" BRASS NIPPLE
3	3/4", 1", 1-1/2", 2" BRASS 90 DEG ELBOW, MPT x GJ (FORD L84-xx-G-NL)
4	3/4", 1", 1-1/2", 2" BLUE PE WATER SERVICE TUBING, CTS, SDR-9
5	3/4", 1", 1-1/2", 2" 1/4 TURN BRASS BALL VALVE
6	GRAVEL BED (NO. 57 STONE)
7	3/4", 1", 1-1/2", 2" BRASS 90 DEG ELBOW, GRIP JOINT (FORD L44-xx-G-NL)

NOTE: FORD = FORD METER BOX COMPANY

Revision Date: 12/11/2018		Gainesville Regional Utilities Potable Water Construction Details REDUCED PRESSURE ZONE BACKFLOW PREVENTER SINGLE SERVICE: 3/4", 1", 1-1/2", 2"
------------------------------	---	---

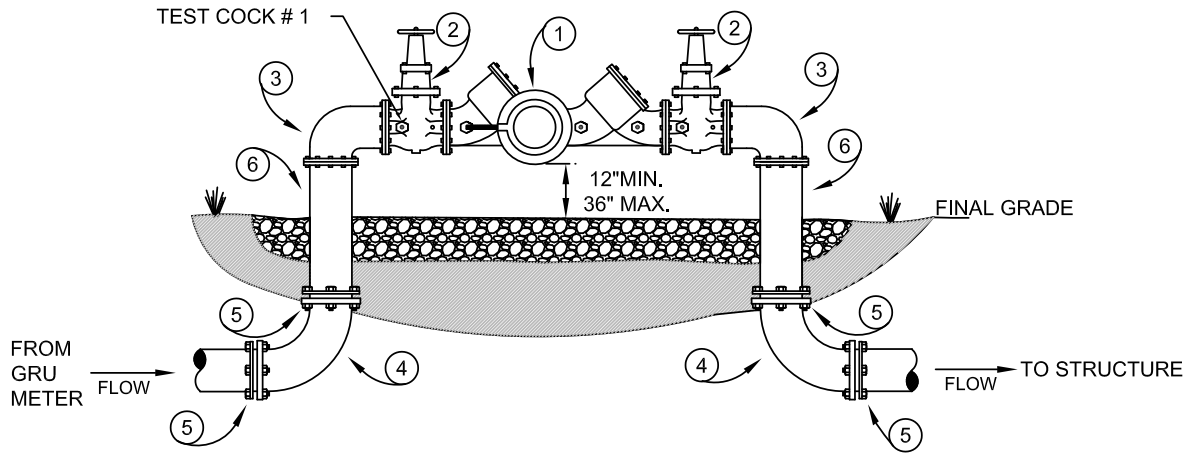

M A T E R I A L S

ITEM	DESCRIPTION
1	REDUCED PRESSURE BACKFLOW PREVENTER
2	GATE VALVE, FL X FL
3	BEND, DI, 90°, FL X FL
4	BEND, DI, 90°, MJ X MJ
5	MEGALUG, EBAA OR APPROVED EQUAL
6	PIPE, DIP, FL X PE

Revision Date:
12/11/18



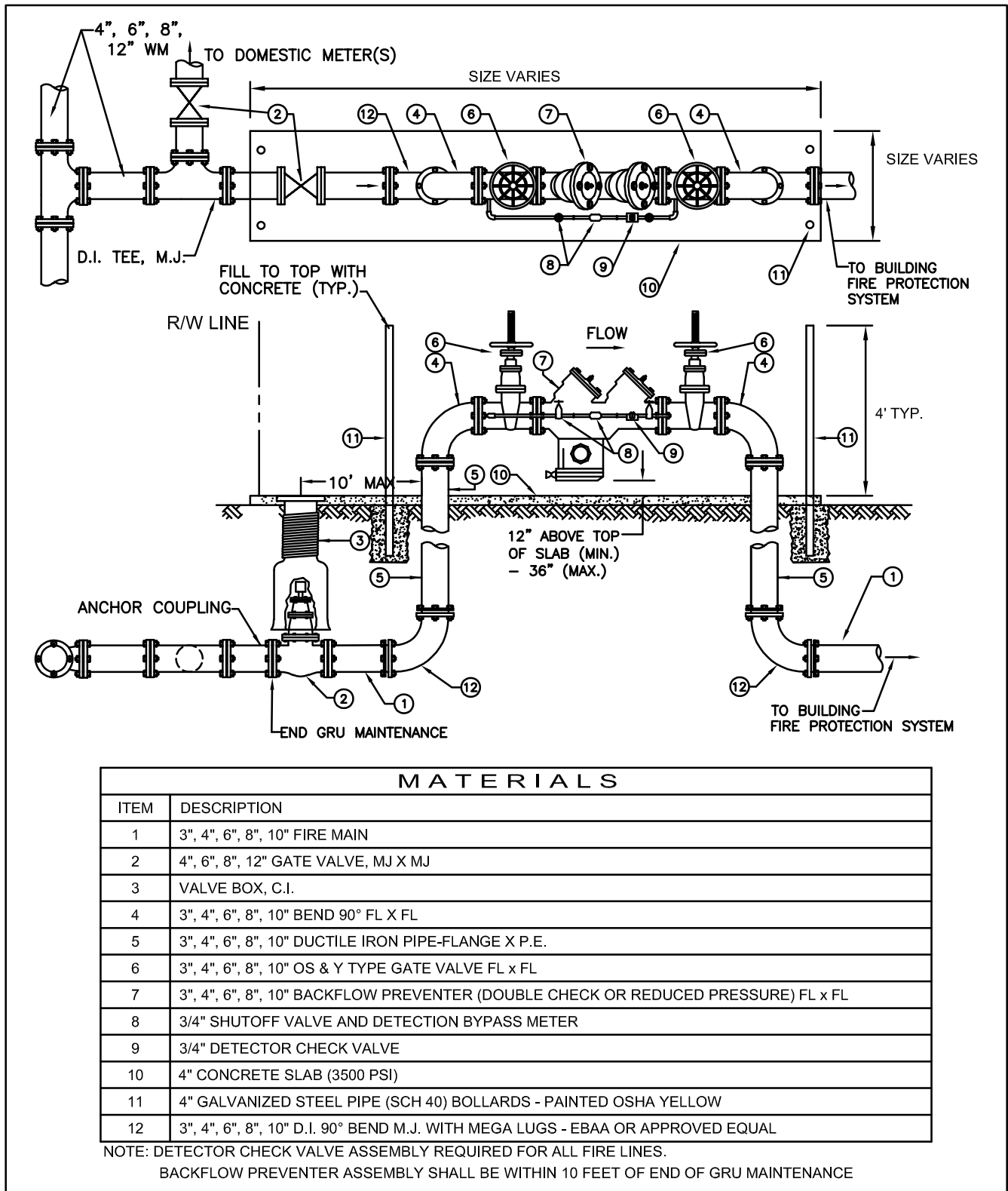

Gainesville Regional Utilities
Potable Water Construction Details

REDUCED PRESSURE BACKFLOW PREVENTER
SINGLE SERVICE: 3" - 10"

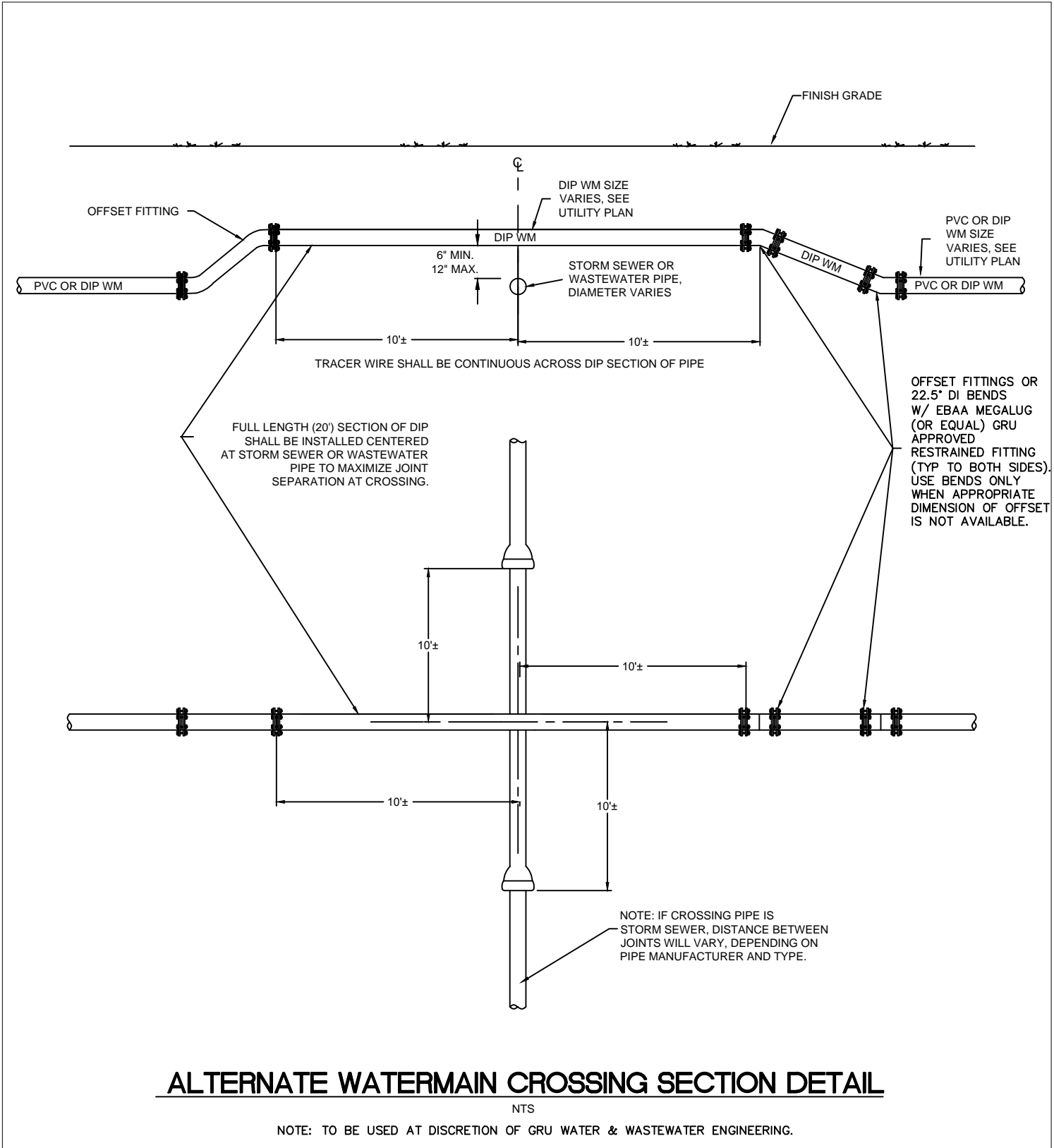

Revision Date: 1/15/2019	<p>GRU More than Energy</p>	Gainesville Regional Utilities Potable Water Construction Details 3", 4", 6", 8", 10" FIRELINE CONNECTION DOUBLE CHECK OR REDUCED PRESSURE BACKFLOW PREVENTER ASSEMBLY
------------------------------------	--	--



<p>Revision Date: 11/02/2018</p>		<p>Gainesville Regional Utilities Potable Water Construction Details</p> <p>ALTERNATE WATERMAIN CROSSING SECTION DETAIL</p>
--------------------------------------	---	--

TREE - WATER SEPARATION

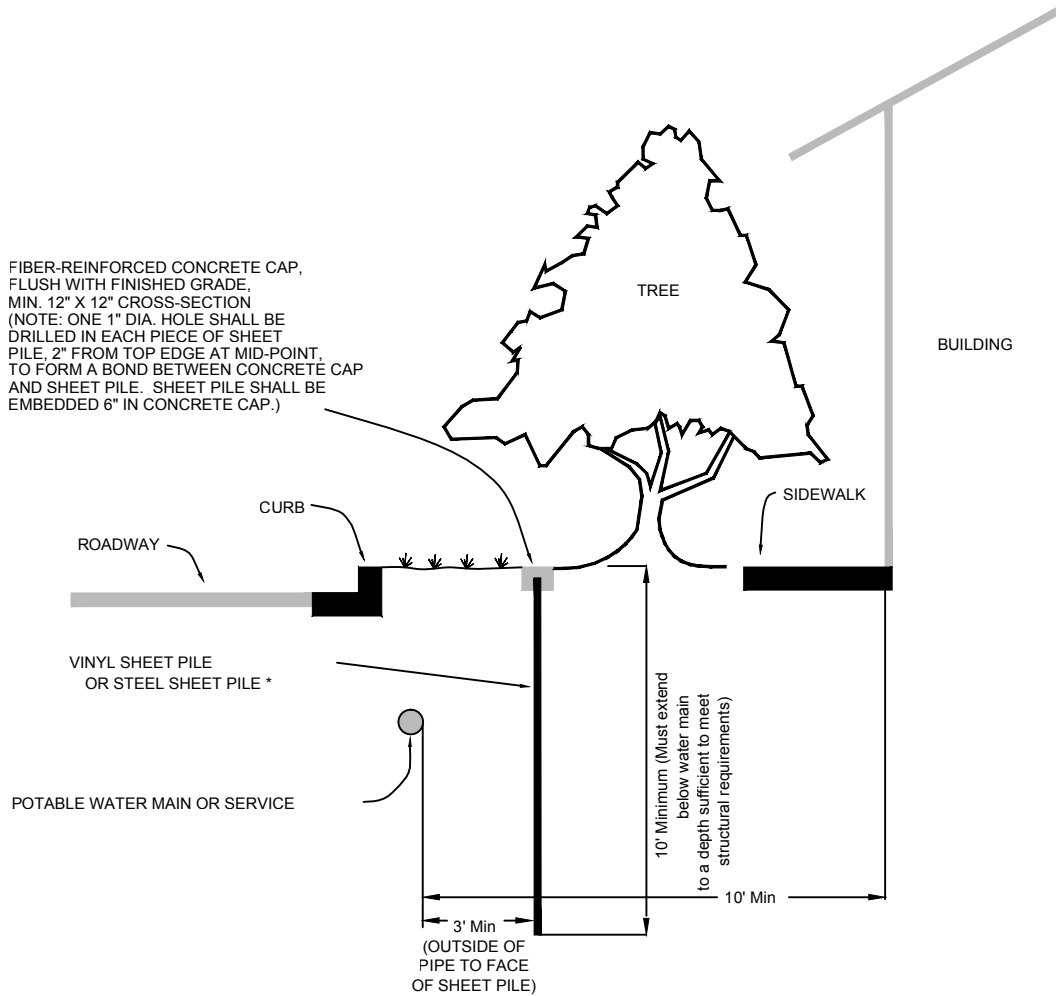

SHEET PILE

ALTERNATIVE PIPE PROTECTION FOR SEPARATIONS LESS THAN 7.5 FEET FROM TREES.

ALL DISTURBED EARTH OR NEW BACKFILL SHALL BE COMPACTED TO 95% OF MODIFIED PROCTOR (ASTM D 1557)

*Sheet pile joints to be filled with 50 year silicone caulk prior to placement.
(If installation is open trench)

Revision Date:		Gainesville Regional Utilities Potable Water Construction Details
8/31/09		

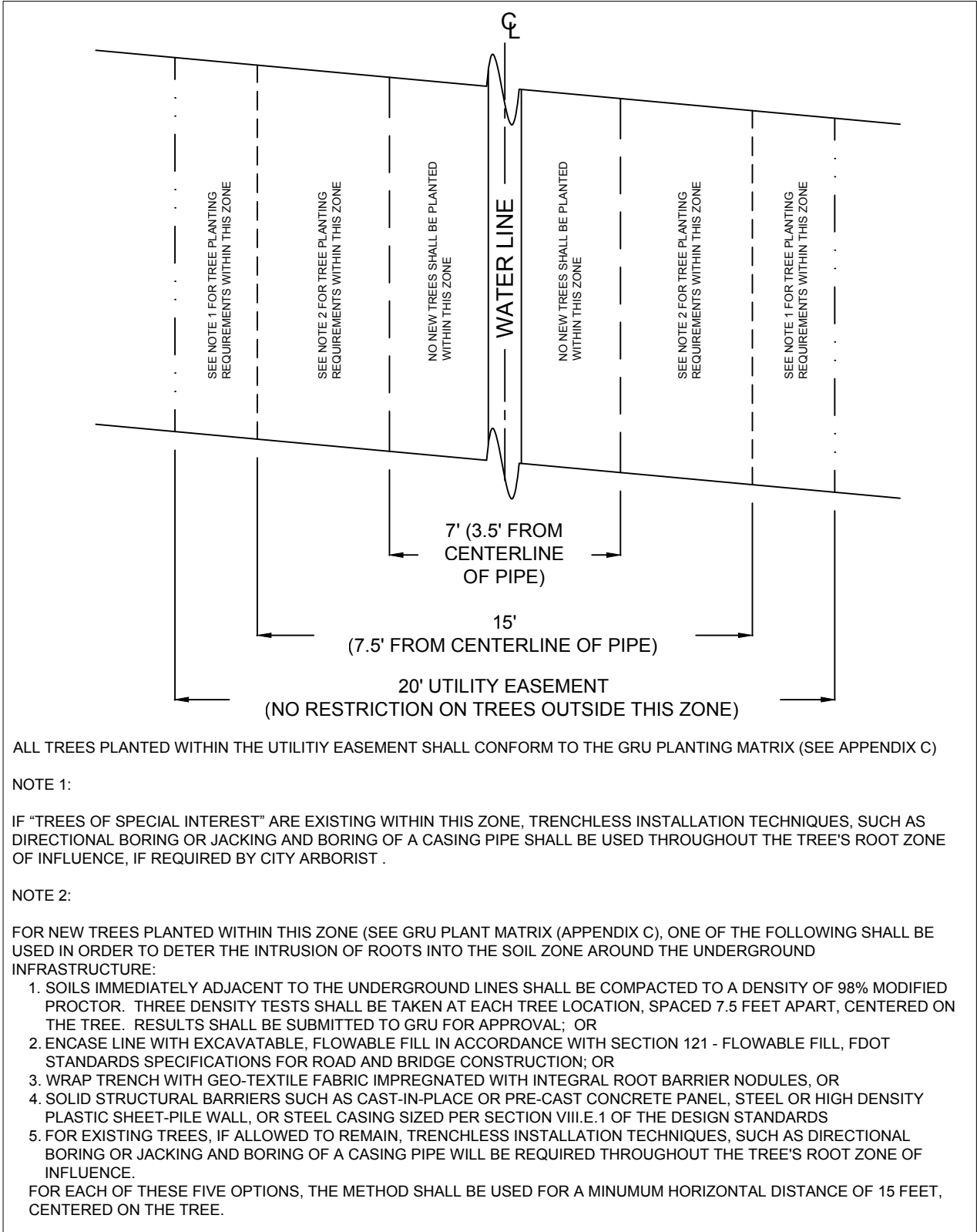

<p>Revision Date: 8/28/09</p>	<p style="text-align: center;">GRU More than Energy</p> <p style="text-align: center;">Gainesville Regional Utilities Potable Water Construction Details</p> <p style="text-align: center;">TREE SEPARATION FROM POTABLE WATER MAINS AND SERVICES</p>
-----------------------------------	---